

中国高端电脑缝纫机

CHINESE HIGH-END COMPUTERIZED SEWING MACHINE

HIKARI® 富山

使用说明书

INSTRUCTION MANUAL

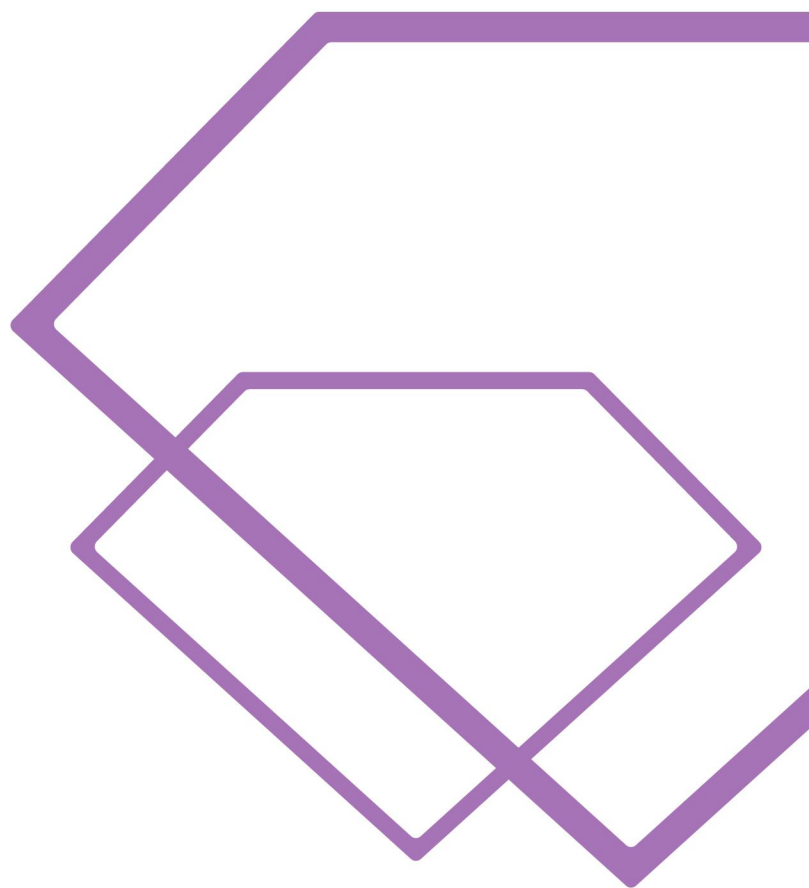



HXT6900TA 系列
Series

电脑气动上下送布细嘴包缝机

COMPUTER DIRECT DRIVE CYLINDER BED
OVERLOCK SEWING MACHINE

V1.00

重要安全事项

1. 使用此缝纫机时，必须遵守包括如下项目的基本安全措施。
2. 使用此缝纫机之前，请阅读使用说明书在内的所有指示文件。同时应该将此使用说明书妥善保管，以便能够随时查阅。
3. 使用此缝纫机和缝纫机动作中，所有的安全装置应安装到规定的位置。没有安装规定的安全装置的缝纫机禁止使用。
4. 此缝纫机应由接受过培训的操作人员来操作。
5. 使用缝纫机时，建议戴安全防护眼镜。
6. 发生下列情况时，应立即关掉电源开关，或拔下电源线插头。
 - 6-1 机针、弯针、分离器等穿线和更换旋梭时。
 - 6-2 更换机针、压脚、针板、弯针、分离器、送布牙、护针器、支架、布导向器等时。
 - 6-3 修理时。
 - 6-4 工作场所无人了或离开工作场所时。
7. 缝纫机以及附属装置使用的机油、润滑脂等液体流入眼睛或沾到皮肤上时，或被误饮时，应立即清洗有关部分并去医院治疗。
8. 禁止油手触摸打开了缝纫机开关通电的零件或装置。
9. 有关缝纫机的修理、改造、调整应由受过专门训练的技术人员或专家来进行。
10. 一般的维修保养应由受过训练的人员来进行。
11. 有关缝纫机的电器方面的修理、维修应有资格的电器技术人员或专家的监督和指挥下进行。
12. 修理、保管有关空气、汽缸等压缩空气的零件时，应切断空气压缩机供气源后再进行。
13. 缝纫机的使用期间应定期进行清扫。
14. 为了正常安全运转，应安装地线。同时应在不受高频焊接机等强噪音影响的环境下使用。
15. 电源插头应用具有电器专门知识的人来安装。电源插头必须连接到接地插座上。
16. 缝纫机指定用途以外不能使用。
17. 对缝纫机的改造、变更应符合安全规格，并采取有效的安全措施。另外，对于有关改造和变更，本公司概不负责。
18. 本使用说明书上采用以下 2 个警告符号。
 -  有损伤操作人员、维修人员的危险。
 -  安全上需要特别加以注意的事项。

为了安全地使用缝纫机的注意事项

危险

1. 为了防止触电事故，请不要在接通电源的状态下打开控制箱的外壳或触摸控制箱内的零件。

注意

- 1 为了防止人身事故的发生，请不要在卸了皮带护罩、眼睛防护罩等安全装置的状态下运转缝纫机。
- 2 为了防止被卷入的人生事故的发生，请使用带电机防护罩的马达。
- 3 为了防止触电事故的发生，请不要卸下电源地线的状态下运转缝纫机。
- 4 为了防止被卷入的人身事故的发生，缝纫机运转途中请不要将手指、头发、衣服靠近皮带轮，也不要东西放到上面。
- 5 为了防止人身事故的发生，打开电源后或缝纫机运转中请不要把手指放到切布刀和机针的附近。
- 6 为了防止人身事故的发生，缝纫机运转中请不要把手指放到眼睛防护罩内。
- 7 为了防止触电、漏电、火灾事故，拔插电源线前一定先关掉分缝机电源，手持电源插头进行插拔。
- 8 为了防止突然启动造成人身事故，离开缝纫机时请您一定关掉电源。
- 9 为了防止突然启动造成人身事故，发生停电后一定关上电源。
- 10 为了防止突然启动造成人身事故，拆卸电机防护罩时，请一定关掉电源，用脚踩踏板确认不动后再拆卸。
- 11 为了防止突然启动造成人身事故，检修、调整、扫除、穿线、换针时，请一定先关掉电源，用脚踩踏板确认不动后再进行。
- 12 为了防止缝纫机落下造成人身事故，搬运缝纫机时请不要手拿布台护罩。拿布台护罩后护罩会打开，缝纫机会掉下来。

目 录

1. 前言.....	5
2. 警告标记.....	5
3. 安全措施	
➢ 使用环境.....	6
➢ 安全措施.....	6
4.各操作过程的注意事项	
➢ 开 箱.....	7
➢ 搬 运.....	8
➢ 安装·准备.....	8
➢ 使用缝纫机油.....	9
➢ 运转缝纫机前的注意事项.....	9
➢ 运转缝纫机中的注意事项.....	9
➢ 维护、检查、修理.....	10
5.警告标签粘贴的位置与安全保护装置.....	11
6.安全保护装置	
➢ 护眼板.....	12
➢ 护指架.....	12
➢ 压脚.....	12
➢ 前护盖.....	12
7.日常操作中了解的常识问题	
➢ 台板的加工图.....	13
➢ 关于供油.....	14
➢ 给 HR 装置供油.....	15
➢ 机油的更换.....	15
➢ 排油的方法.....	15
➢ 检修和更换过滤器.....	15
➢ 缝纫机的清扫.....	15
➢ 穿线的方法.....	16
➢ 机针的更换.....	16
➢ 线状态的调节.....	17
➢ 压脚的开和关.....	17
➢ 压脚压力的调节.....	17
➢ 差动比的调节.....	17
➢ 针脚长度的调节.....	18
➢ 上刀的更换.....	18
➢ 下刀的更换.....	18
➢ 链幅的调节.....	18
➢ 刀的研磨方法.....	19
➢ 设置压脚.....	19

- 针打线片的标准安装位置和调节..... 20
- 针过线件的标准安装位置和调节..... 20
- 弯针打线片和过线件的标准安装位置与打线凸轮打线量的调节..... 22

1. 前言



- 本操作说明书将描述如何注意产品的安全使用。
- 在使用该机器之前，请务必阅读本使用说明书，充分理解及掌握缝纫机的操作、检查、调整、维修等方法之后，再进行使用。

2. 警告标记









在本公司的产品及本书中，为了安全使用产品，根据危险程度将警告表示分别使用，务必注意书中的提示。

警告标签应贴在较醒目的地方。若有标签剥落或污损时，应及时更换，贴上新的标签。如需更换用新的标签，请联系本公司销售部。

提醒注意的标记以及报警用语

 危险	表示危险性极大，弄错操作等时会有可能至于死亡或受重伤的危险。
 警告	操作有误时，会至于受重伤，甚至发生死亡事故的危险。
 注意	操作有误时，有可能受轻伤或中等伤害，或会发生损伤物质的危险。

说明图表记号

	必须严守指示，应按其内容准确操作
	万一弄错操作，会有触电的危险。
	弄错操作，会招致手指受伤。
	有接触高温烫手受伤的危险。
	绝对禁止。
	需要进行修理、调整等维修工作时，或有可能落雷的危险时，应预先把电源插头由供电的插座拔掉，以免意外。
	连接地线
	表示缝纫机传动轮旋转方向。

3. 安全措施

➤ 使用环境

使用的环境有可能给缝纫机的寿命、性能及安全性带来不良影响。



为了安全保护，请勿在下述环境条件之下使用。

1. 在靠近高频焊接机等产生干扰的机器设备旁边。
2. 产生药品蒸气气氛的地方，及受药品飞溅等地方使用或保管。
3. 屋外、高温高湿、直接曝晒阳光的地方。
4. 周围的温度、湿度很大，会给缝纫机带来坏影响的地方。
5. 额定电压常超过±10%以上的电压变动较厉害的地方。
6. 电源容量无法确保控制马达规格上所需要的容量时。

➤ 安全措施



(1) 进行维修保养、检验时的安全保护

- 在对缝纫机进行检查、修理、清扫等维护作业时，请关掉电源开关，将电源插销从插座上拔下，并确认踩缝纫机踏板也不会转动之后再进行操作。
但是，有必要接通电源进行作业时，请制定防止缝纫机以外转动或操作者错误而导致危险的安全操作准则，并遵守一切安全防护准则。
- 在进行以下作业时，务必关掉电源开关，将电源插销从插座上拔下之后进行。
 - 加油
 - 穿线
 - 打扫缝纫机
 - 换机针
 - 进行供油元件的清扫和更换时
 - 更换机油
- 在进行以下作业时，请务必关掉电源开关之后进行。
 - 调节针脚时
 - 调节差动比时
- 实施定期检修、保养时，应限由充分熟练省力装置以及缝纫机的维修工作的专门技术人员来进行。



- 请勿按客户的任意判断而加以改造或更改，会招致事故的原因。

※如有改造或更改的需要，应先联系经销商或本公司销售部询问。



(2) 开始运转前的检验事项

- 在开始操作运转缝纫机前，先检查缝纫机缝纫部分，看是否有损伤、功能不良等问题。万一有异常现象时，应马上修理或采取必要的措施。
- 务必先确认针箍是否固定好。
※请注意针尖有危险。
- 在使用缝纫机之前，务必确认压脚是否在正确的位置。（用手轻轻转动手轮，看针尖是否落在压脚的针孔中心）（图 1）
- 务必检查压脚是否牢固的固定好。（使用抬压脚机构抬起压脚，用手前后左右扳动，检查压脚是否松动）（图 2）



图 1



图 2

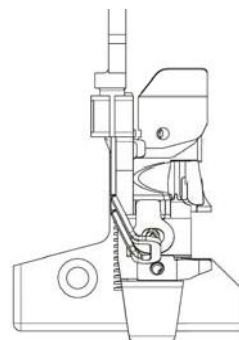

(3) 培训

- 为了防止事故，操作人员及维修员应先掌握机器的使用和有关技能。

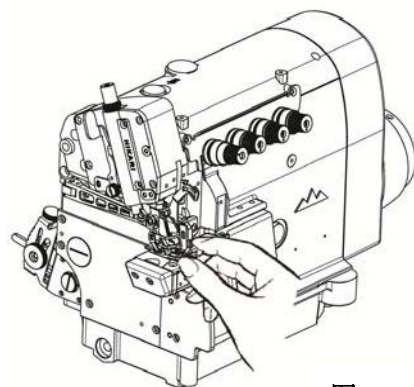
4. 各操作过程的注意事项

➤ 开箱

1. 缝纫机机头出厂时包装好后装入纸箱运出的。从印刷在纸箱上的标记字样确认上下后，请从上到下按顺序开箱。
2. 把缝纫机机头从缓冲包装材料里拿出时，绝对不要提拿与机针部位或过线器等有关的部件，否则会发生危险或损伤机器。
3. 在取出缝纫机机头时，请注意重心的位置，小心谨慎的取出。
4. 开箱用过的纸箱如果以后还用的话，请好好保存放好。

包装材料的处理

- 包装材料包括木头、纸张、纸箱、VCE 纤维。请顾客将包装材料正确适当的进行处理。

缝纫机废物的处理

1. 缝纫机的废物，请客户负责进行处理。
2. 制造缝纫机使用的材料有铁、铝、锌及各种材料。
3. 缝纫机的废物应遵照当地环境保护的有关规定进行处理。必要时委托专门的厂家进行处理。

※有油污的部件务必遵照当地环境保护的有关规定，分别进行处理。

警告

➤ 搬运

1. 缝纫机机头的搬运一定要两个人以上进行。另外，用人直接搬运应只限于搬往缝纫机台板或小台车进行。
2. 移动缝纫机机头时，用右手抓住手轮及电机罩，左手垮在机头里，扎实牢固的搬起。（图3）
缝纫机上沾有油污在搬运时容易滑脱摔坏，搬运请好好擦净机头上的油污。
3. 在往缝纫机台板上或小台车上搬运时，请注意不要过分冲击或震动，以免缝纫机倒斜造成危险。
4. 如果要第二次运送缝纫机并要包装时，请一定擦干净机头上的油污。否则，搬运时会滑脱摔坏机头或油污使包装材料变质穿底。



图 3

注意

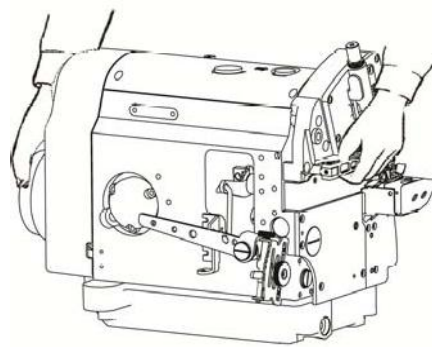

➤ 安装·准备

缝纫机台板

- 1 请使用能充分承受缝纫机机头重量及搬运时产生的反作用力的缝纫机台板（台板、铁架）。
- 2 应充分考虑缝纫机装配部件和操作光线的明亮度，放置在容易作业的环境中。如果光线不是十分明亮时，应根据需要安装照明电灯。
- 3 在运转缝纫机时，为防止操作者踩踏板时脚滑脱造成事故，一定要在缝纫机踏板上安装防止滑脱的垫子。
- 4 根据操作者操作的姿势，调整台板面的高度（工作时的高度）。

警告

接线

1. 请牢固的查好缝纫机机头与电机连接线的插头。
缝纫机机头与电机用连接线进行连接时，务必在将电源开关关闭的状态下进行操作。
2. 在使用中请不要给连接线过多的力。
3.  请不要过度弯曲连接线。
4. 接近运动部件的连接线，应最小距离在 25mm 处进行安装。
5. 必要时考虑连接位置或加设护罩来保护连接线。
6.  固定连接线时绝对不要使用书针。

注意

接地

1. 接地线是按每台缝纫机分别装设专用的接地线，不应与其他机器共用。
2.  在缝纫机机头的规定地点准确地装设接地线。

警告

➤ 使用缝纫机油

1. 在油盘内没有注入油之前绝对不要运转机器。机油请使用指定的缝纫机专用润滑油。（相当于 ISO 粘度等级 VG22）。
2. 机油进入眼睛会使眼睛发炎，所以在使用时请戴防护眼镜以免机油进入眼睛。
※万一进入眼睛，请用干净水冲洗 15 分钟，再请医生治疗。
3. 接触皮肤后，请马上用水和肥皂洗干净。
4.  绝对不要使机油进入口腔。
5. 机油请保管在孩子摸不到的地方。万一进入口腔，不要硬性呕吐，马上请医生进行治疗。
6. 废油、废容器的处理方法必须遵照环境保护法相关的措施正确处理。如不知道请与经销商联系后，再进行处理。
7. 为了防止灰尘、水分的混入，使用完后保管机油时请盖紧油箱盖，放在没有阳光直射的阴凉处保管。

警告



➤ 运转缝纫机前的注意事项

缝纫机台板

1. 打开电源前，请确认接线或接头是否有损伤、脱落、松动等外观上的异常。
2.  打开电源时，请不要将手放在机针附近或自动切线装置剪刀。
3. 操作缝纫机者应为受过培训、充分理解本书及使用说明书的内容之后，再进行操作使用。
4. 关于缝纫机机头上的危险、警告标志应熟读并理解[2.警告表示]，必要时应对使用者进行安全教育。
5. 最初使用的一个月应降低速度。请使用在最高转速的 3/4 以下的转速。

警告

➤ 运转缝纫机中的注意事项

1.  在拆卸下护眼板、护指架、传动护罩等安全装置下，请不要运转缝纫机。
2.  缝纫机在运转中是很危险的，绝对不要将手放入机针下。
3. 缝纫机在运转中有危险，手指、头发、衣服请勿靠近针杆和自动切线装置剪刀附近。
同时，在上述场所，请勿放置剪刀、镊子、工具等。
4. 在不使用缝纫机时或者操作者离开缝纫时，一定要将电源开关关掉。
5. 停电时务必将电源关掉。
6. 在操作缝纫机时，请穿着不易被机械卷入的服装。
7. 缝纫机在运转中，请不要在缝纫机台板上放置工具及其他与缝纫无关的物品。



注意

➤ 维护、检查、修理

1. 维护、检查、修理的作业应由受过特别训练的人并在充分理解本书及使用说明书的内容之后，再进行作业。
2. 为了维护、检查、修理要将缝纫机机头放倒时、务必将电源开关关掉，把电源插头从插座上拔下，并确认即使踩缝纫机踏板缝纫机也不会转动之后，再进行操作。
3. 对于缝纫机机头的日常检查或定期检查，应按照本书及使用说明书的指示，切实认真的进行。
4. 缝纫机的修理或部件的更换请使用原装部件。对于不恰当的修理、调整或使用假冒伪劣部件所造成的事故，本公司将不负一切责任。
5. 请不要根据顾客自己的判断对缝纫机进行改造。否则因改造而发生事故，本公司将不负一切责任。
6. 临时因修理、调整而拆卸下的安全装置、安全护罩，待作业完成后务必按原来的状态安装好。
7. 维护、检查、修理的作业完成后，请检查接通电源之后是否确实没有危险。

5. 警告标签粘贴的位置与安全保护装置



图 4

6. 安全保护装置

这个项目是为了使大家都知道各种安全保护装置，并记载了各部分的注意事项。

注意

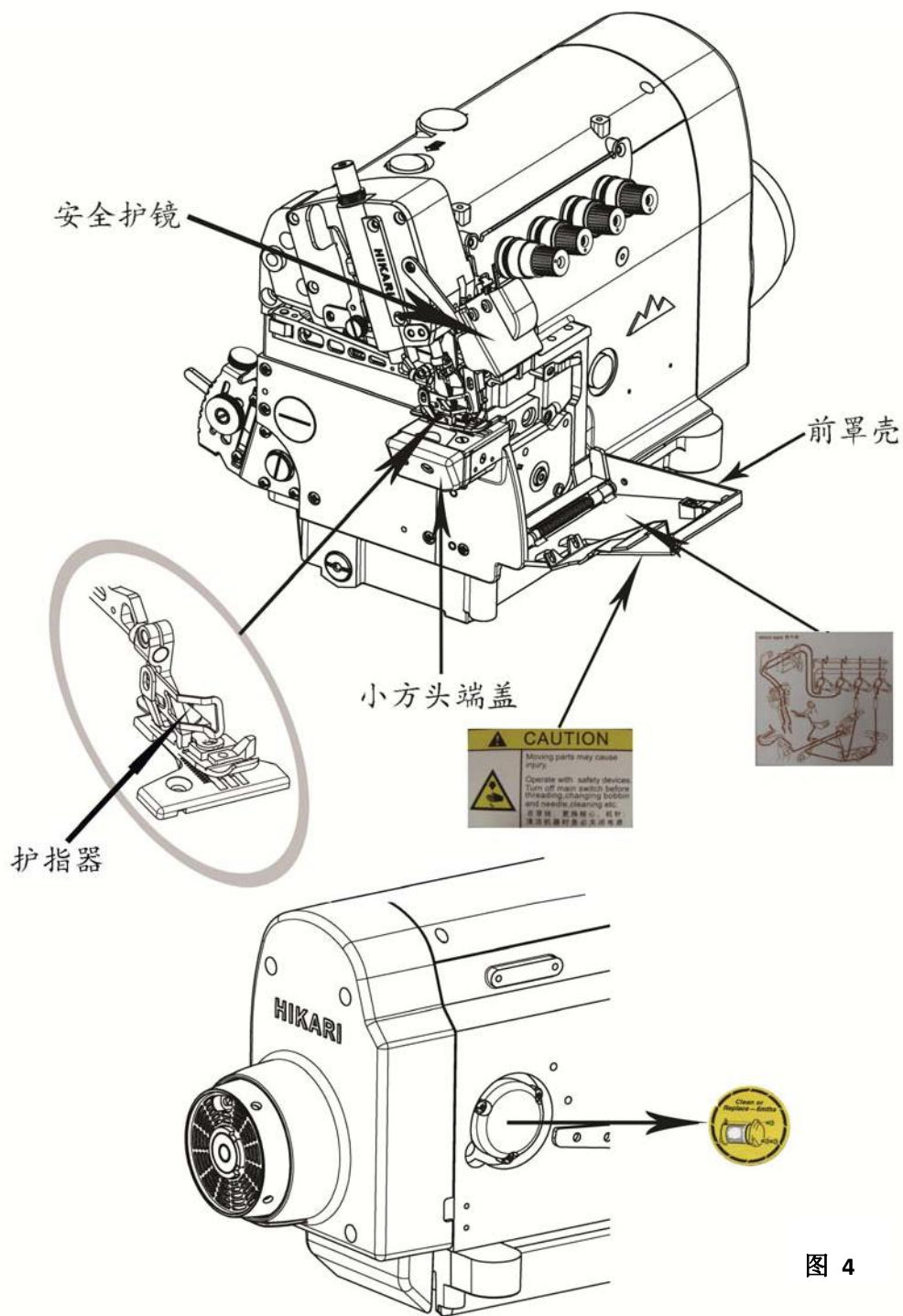
安全保护装置

➤ 护眼板

⊘ 不要打开

为了眼睛的安全，绝对不要在打开护眼板的状态下操作缝纫机。护眼板是为了在缝纫中针断了时，使断针不会飞入眼睛而安装的护眼罩。

➤ 护指架

⊘ 不要把手伸入

为了防止上下运动的机针与人接触而产生危险，在机针附近安装了护指架。但是，在护指架上方为了便于穿线而留有间隙，如果将手指从间隙伸入，机针有可能会刺上手指造成危险。

➤ 压脚

⊘ 不要把手伸入

从针板表面压脚的上升量是 5mm 以上，这个间隙有夹手指的危险。在用膝盖开关抬升压脚时或用踏板自动抬升压脚时，请不要将手指伸入压脚上方。

➤ 前护盖

⊘ 不要把手伸入

弯针的运动从缝纫机正面看时，是进行左右往复的圆弧运动。为了避免进行圆弧运动的弯针与人接触，务必请在前盖板闭合的状态下操作缝纫机。

➤ 护指片

⊘ 不要把手伸入

在电源开关开启的时候，绝对不要将手指伸入护指片内，防止机器产生误信号动作，导致剪线刀损伤手指造成危险。

7. 日常操作中应了解的常识问题

➤ 台板的加工图





图 5

➤ 关于供油

 注意

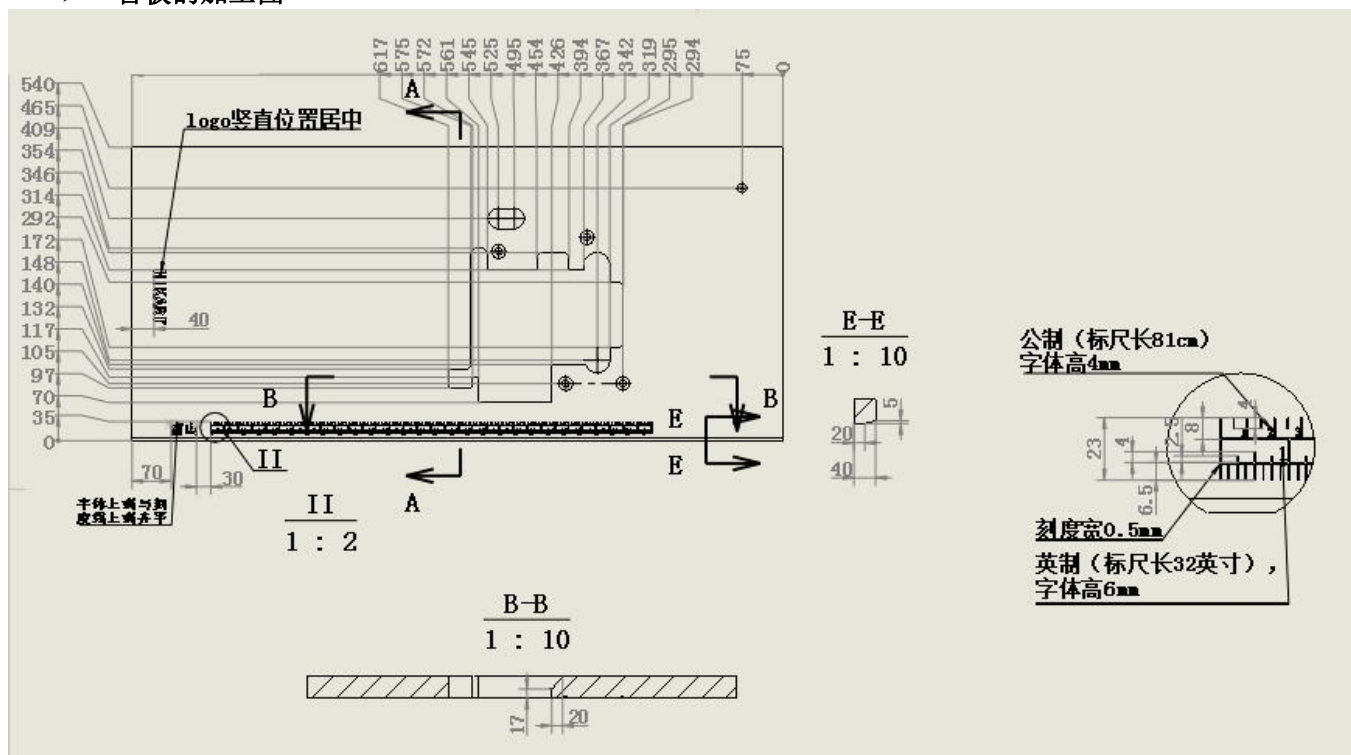
 在加机油或换机油时，请务必使用本公司提供的机油。如果使用提供以外的机油，有可能损坏缝纫机。

1. 使用的油类

请使用本公司提供的“HIGH SPEED SEWING MACHINE OIL”（高速低粘度润滑油）（ISO 粘度等级/VG22）

2. 供油的方法(图 6)

揭开供油口的盖子,加油至油面到达油标尺的H线和L线中间。加完油后，请盖好供油口的盖子 1。

3. 油的规定量（图 6）

油标尺 2 的 H 线和 L 线表示着油量的上限和下限。

为使油面经常保持在 H 线和 L 线之间，请常常检查注意加油。

4. 用手加油（图 7）

 注意

在用手加油时，务必将缝纫机的电源关掉，将插头从电源插销上拔下来之后再行。

第一次使用缝纫机时，以及使用已有一段时间没有使用的缝纫机时，请用给油瓶在针杆 3 和上弯针台 4 处分别给油 2~3 滴。

5. 检查机油的循环状况（图 8）

请在加完油后，踩下缝纫机踏板，使缝纫机运转，通过油窗 5 检查机油的循环状况是否良好。



图 6



图 7

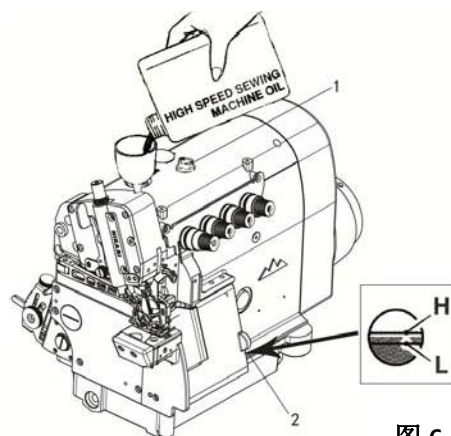

图 8

➤ 给 HR 装置供油

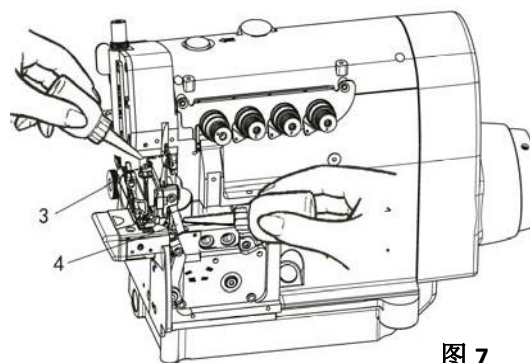
注意

在给 HR 装置供油时，务必将缝纫机的电源关掉，将插头从电源插销上拔下来之后再行。

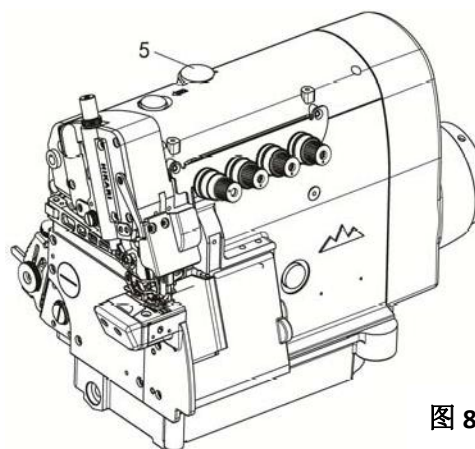
在 HR 装置的硅油盒 1 和 2，为了防止机针断线加有硅油。请经常检查，请尽早补充硅油。（图 9）



图 9

➤ 机油的更换

注意

更换油时，请专业技术人员进行操作。

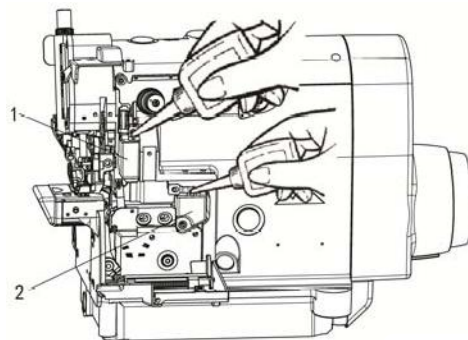
缝纫机在开始使用 1 个月后更换一次机油，然后请 6 个月更换一次机油。如果不更换机油继续使用，缝纫机有可能发生故障。



图 10

➤ 排油的方法

1. 请卸开油箱底座排油孔螺丝 3，排出旧油。
2. 排完油后，将排油孔螺丝 3 拧紧。（图 10）

➤ 检修和更换过滤器

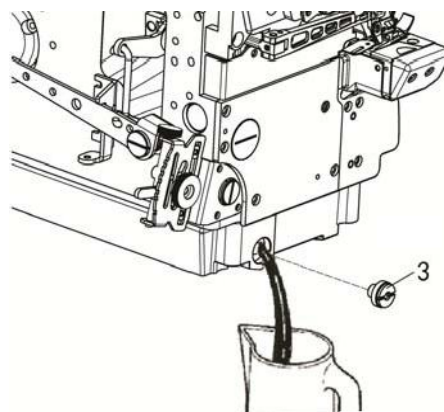
注意

检修和更换过滤器时，务必将缝纫机的电源关掉，将插头从电源插销上拔下来之后，请专业技术人员进行操作。

当过滤器 7 有脏物等堵塞时，就不能正常给油。请每 6 个月拆卸过滤器 7，进行清扫或更换。

过滤器的拆卸方法（图 11）

请参考图，拆下 4~7 后，检查过滤器。当发现过滤器 7 伤痕严重无法使用时，请更换新的过滤器。



图 11

➤ 缝纫机的清扫

注意

在清扫缝纫机时，务必将缝纫机的电源关掉，将插头从电源插销上拔下来之后再行。

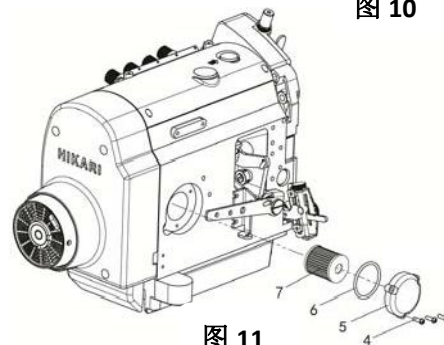
请打扫针板的空槽和送布牙周围。（图 12）



图 12

➤ 穿线的方法

 注意

在进行穿线时，务必将缝纫机的电源关掉，将插头从电源插销上拔下来之后再行。

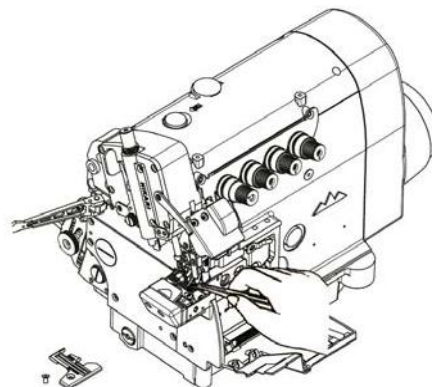
1 请打开翻盖 1、护眼罩 2、前罩 3、抬压脚臂 4。穿过线以后，请恢复到原来的位置。（图 13）

2 如果已穿好线时（图 14）

A 部：请将已穿好的线与缝纫机用线连接起来。

B 部：针线把线的接头拉到针的跟前，先将接头剪掉，再将线穿过针。

C 部：弯针线 可一直将连接的接头穿好后，再用剪刀剪掉线头整好。

3 当缝纫机上没有线时

看着贴在缝纫机上的穿线图，将线穿过去。



图 13



图 14

三、四线

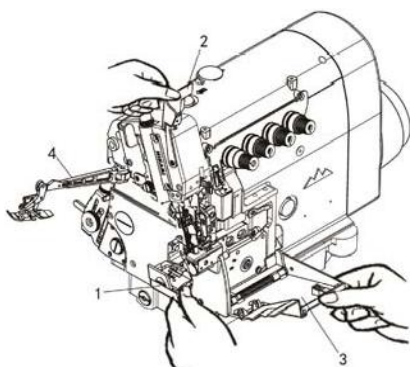

图 15

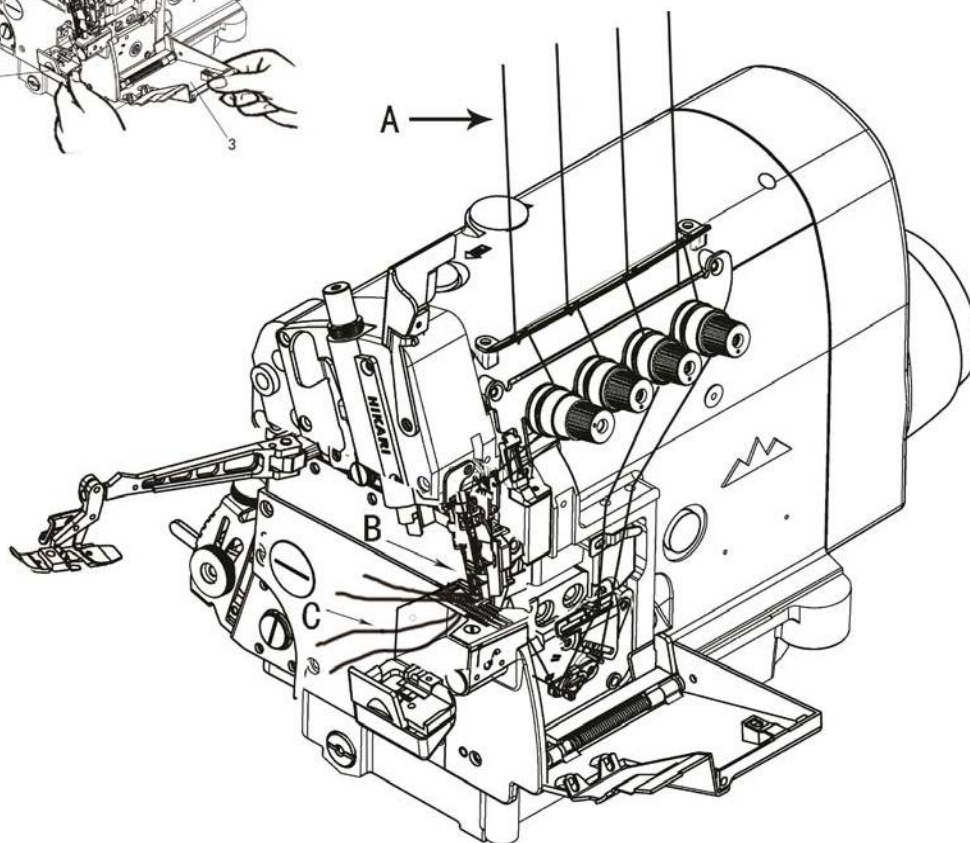

➤ 机针的更换

注意 在更换机针时，务必将缝纫机的电源关掉，将插头从电源销上拔下来之后再行。

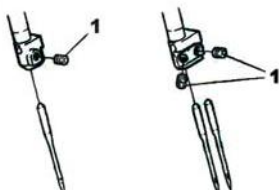
请松动螺丝 1（但不能拔出螺丝），更换针。（图 15，16）

安装时，将针的凹槽部朝向正后方，插入针箍的针孔中于最底端，拧紧螺丝 1。（图 17）



图 16

➤ 线状态的调节

线状态的调节请用针线调节旋钮 1、上弯针线调节旋钮 2 和下弯针线调节旋钮 3 进行调节。（图 18）

想将线拉紧一些时，可将各旋钮向右旋转，想松一些时可向左旋转。在能取得均匀且漂亮缝纫效果的情况下，尽量采用较松的夹线状态。

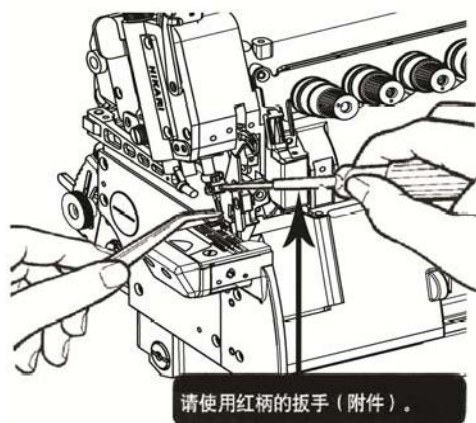
➤ 压脚的开和关



注意

开和关压脚时，务必将缝纫机的电源关掉，将插头从电源插销上拔下来之后再行。

打开压脚时，（图 19）

1. 旋转手轮，将针置于最上边位置。
2. 压下压脚开关把手 1，打开抬压脚臂 2。

合上压脚时，（图 19）

1. 旋转手轮，将针置于最上边位置。
2. 压下压脚开关把手 1，将抬压脚臂 2 返回到原来的位置。

➤ 压脚压力的调节

压脚的压力在送布能正确的进行，并且能缝出稳定针脚的范围内，请尽量使用较小的压力为宜。

旋转调节螺丝 3，调节压脚的压力。（图 20）

➤ 差动比的调节

1. 松动螺母，将把手压下时差动比变大，缝好的布料会收缩。抬起把手时，差动比变小，缝好的布料会伸长。
2. 调节结束后，请拧紧螺母。（图 21）



图 17



图 18

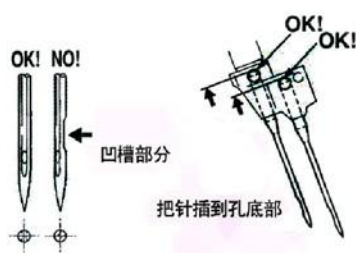

图 19

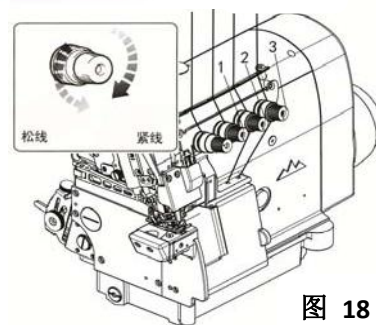

图 20

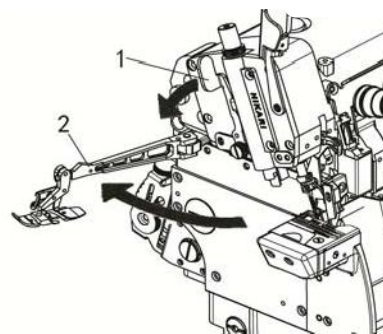

图 21

➤ 针脚长度的调节

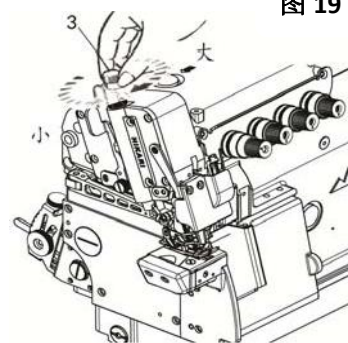
⚠ 注意

在调节针脚长度时，务必将缝纫机的电源关掉，将插头从电源插销上拔下来之后再行。

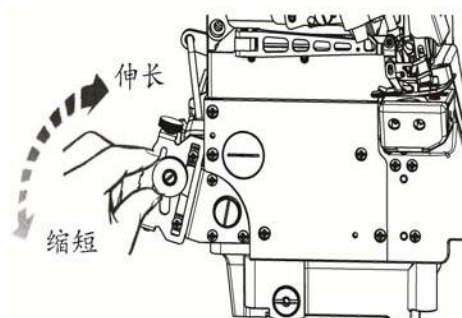
- 1 一边按着按钮 1，一边旋转手轮 2，将按钮置于更深的状态。（图 22）
- 2 顺时针方向旋转手轮，针距变大；逆时针方向旋转手轮，针距变小。

注

缝纫针脚长度的调节，请务必在调节差动比之后进行。



图 22

⚠ 注意

调节刀片时，务必将缝纫机的电源关掉，将插头从电源插销上拔下来之后，请专门的技术人员进行操作。

刀片的刃部有划破手指的危险，操作时要特别小心注意。

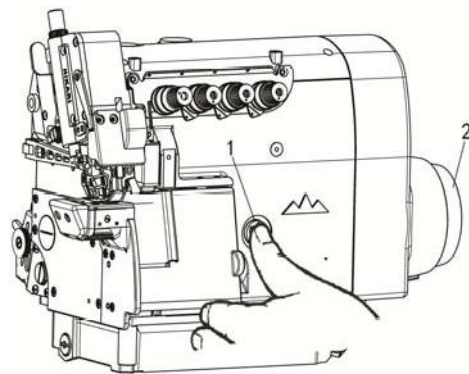
➤ 上刀的更换

- 1 请松动螺丝 1，使下刀架 2 靠向最左边位置，使用螺丝 1 临时固定。
- 2 请拔出螺丝 3，拆掉上刀 4。用螺丝 3 临时固定新的上刀，旋转手轮，将上刀架置于最下边位置，上下移动上刀进行调节，使上刀和下刀相互咬合 0.5~1.0mm 的深度，拧紧螺丝 3。
- 3 将上刀 4 的刀中央 (A) 点对准与下刀 5 的刀中央部相交叉的位置（请参照图 26），松动螺丝 1，确认上刀和下刀没有间隙之后，拧紧螺丝 1。
- 4 在上下刀之间放入线，旋转手轮，确认可以顺利切断线。



图 23

➤ 下刀的更换

- 1 松动螺丝 1，将下刀架 2 置于最左边位置，用螺丝 1 临时固定。
- 2 松动螺丝，取出下刀，更换新的下刀。调节下刀，使下刀的刀刃与针板上面的间隙尺寸为 0~0.3mm，拧紧螺丝 5。
- 3 根据更换上刀的项目 3.~4. 进行操作。

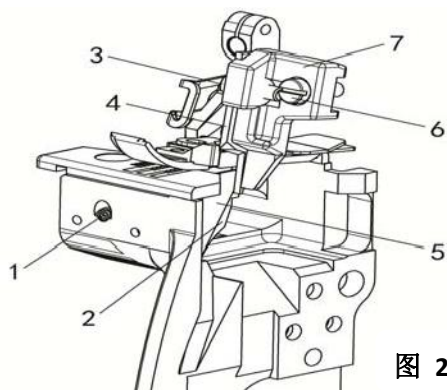

图 24

图 25

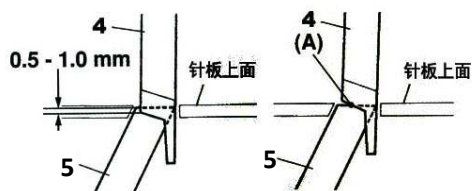

图 26

➤ 链幅的调节

- 1 松动螺丝 1，将下刀架 2 置于最左边位置，用螺丝 1 临时固定。
- 2 松动螺丝 6，左右移动上刀座 7，调节链幅。
- 3 根据更换上刀的项目 3.~4. 进行操作。

➤ 刀的研磨方法

上刀的材质为超硬合金，可在很长时间内不需要研磨。刀的切断变钝时，请研磨下刀。



图 27

下刀的研磨方法（图 27）

请参照图示正确地进行研磨。

研磨方法不对时会使刀变钝，不能很快切断，请予注意。

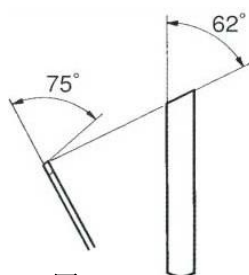
上刀

研磨上刀时，需要使用特殊的研磨机，最好由购买特约店委托我公司代为研磨。为了提高作业效率，请准备好备用上刀。

➤ 设置压脚

⚠ 注意

在改变压脚支点时，请先从插座拔出电源插销，并请专业技术人员为之。

1. 请设置压脚，使送布牙处在最下边位置。
2. 请一边将压脚轴按向箭头方向 A，一边使挡环向右边方向靠近，拧紧螺丝。（此时，请进行调节，以使抬压脚杠杆与上限位螺丝之间留出 1mm 左右的游隙。）
3. 确认压脚的针槽与针板是否一致。若不一致，请松开固定压脚轴套螺丝，左右转动抬压脚臂并进行调节。调节完以后，请拧紧螺丝。（图 28、图 29）



图 28



图 29

➤ 针打线片的标准安装位置和调节

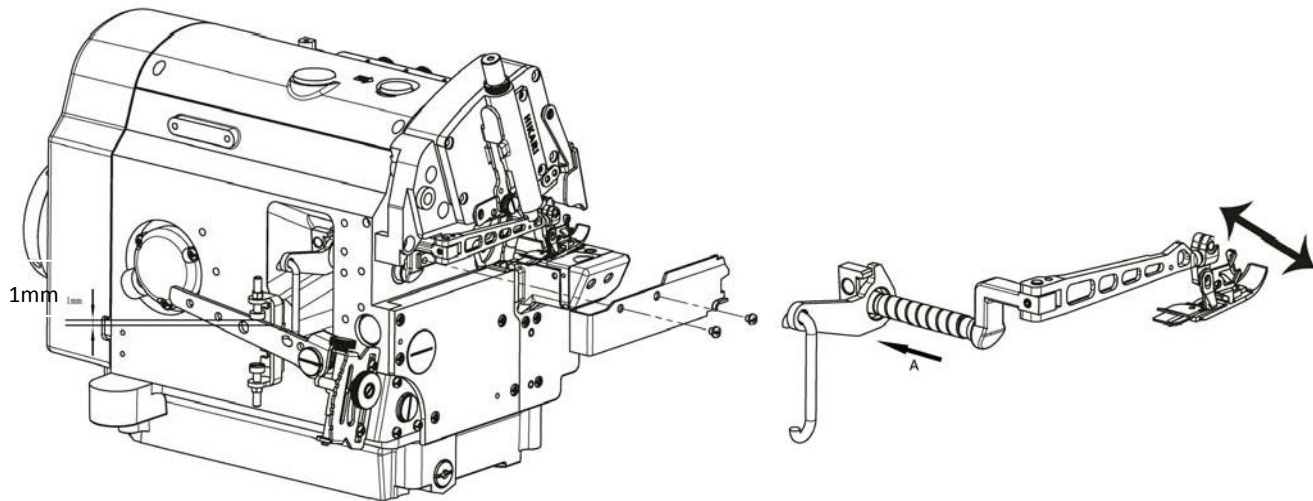
 注意

调节针打线片时，务必将缝纫机的电源关掉，将插头从电源插销上拔下来之后，请专业技术人员进行操作。

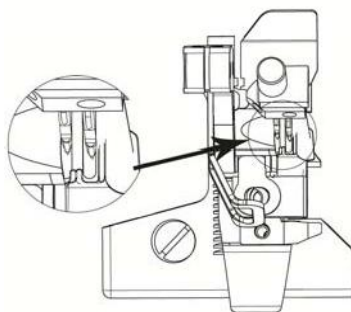
转动手轮当针打线片 1 处于最下方的位置时，请调节上节头部前面到针打线片的尺寸。进行调节时，请松动螺丝 2 进行调节。（图 30、31）



图 30

三、四线

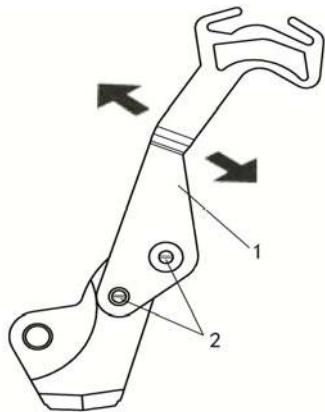

图 31

➤ 针过线件的标准安装位置和调节

针过线件的安装位置因缝纫机的型号而异，以针打线片处于最下方位置和最上方位置时为标准，将各针过线件安装到符合其型号的位置处。

三、四线系列 针过线件调节标准（图 32）

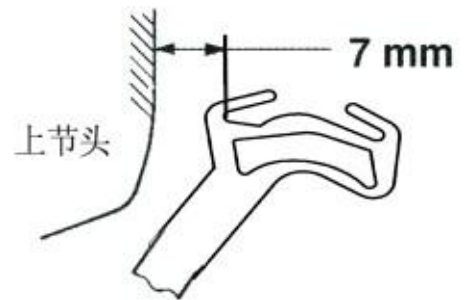
松动螺丝 12 和 14，沿箭头方向移动针过线件和针过线件托架 13 进行调节。

向图中符号 (+) 的方向调节时，线的抽出量增多，向符号 (-) 的方向调节时，线的抽出量减小。调节后，请拧紧螺丝 12 和 14。



图 32₁

调节过线件 11 的左右位置，使针打线片处于双股部分的中心。

针过线件的标准安装位置

● HX6904T-03

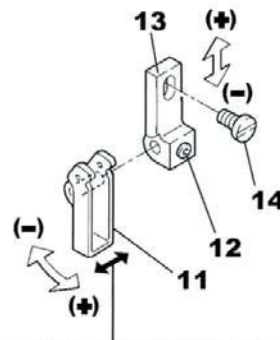
针脚形式: 504

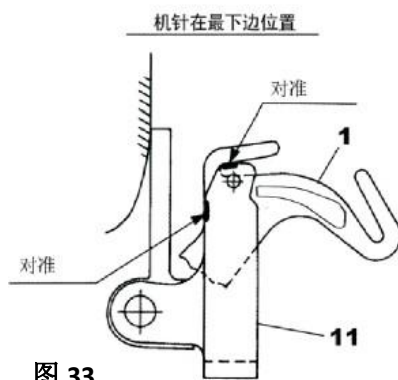

● HX6905T-03

针脚形式: 505



● HX6914T-03

针脚形式: 514

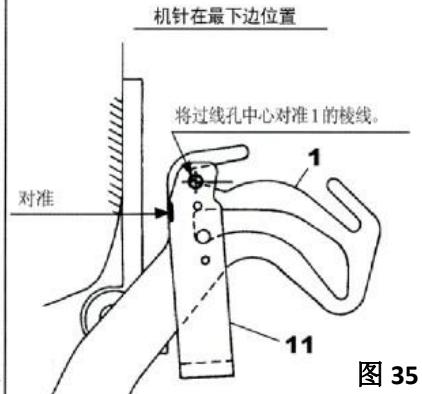

● HX6904T-03

针脚形式: 504 软线链



图 36

➤ 弯针打线片和过线件的标准安装位置与打线凸轮打线量的调节

⚠ 注意

调节打线凸轮时，务必将缝纫机的电源关掉，将插头从电源插销上拔下来之后，请专业技术人员进行操作。

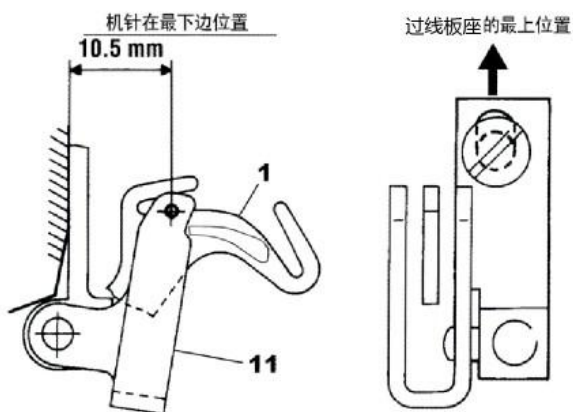
1. 弯针打线片9和11用下弯针最右边位置调节。各自的标准安装位置如下图示。

参与图示，请松动螺丝10和12，调节弯针打线片9和11。

将弯针打线片9和11调节到图中(+)符号的方向时，打线量变大；调节到(-)符号的方向时，打线量变小。

2. 弯针过线件13、15、17的标准安装位置如下图所示。

参考图，请松动螺丝14、16和18，调节各弯着针过线件。

将各弯针过线件向图中的(+)符号调节时，线的打出量增多，向(-)符号调节时，线的打出量减小。(图37)



图 37

弯针打线片和过线件的标准安装位置 (图 38)

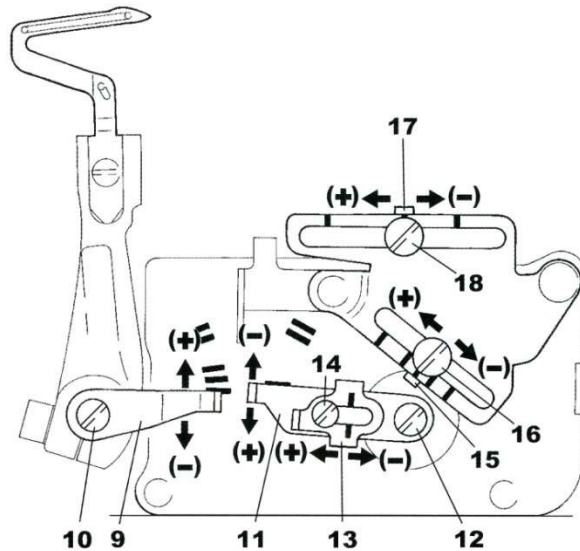

图 38

HX6900T	(a)	(b)	(c)	(d)	(e)
HX6904T-03	26	29	28	21.5	14.5
HX6914T-03	26	29	28	21.5	14.5
HX6904T-04	26	29	28	21.5	14.5
HX6914T-04	26	29	28	21.5	14.5

(mm)

调节基准表

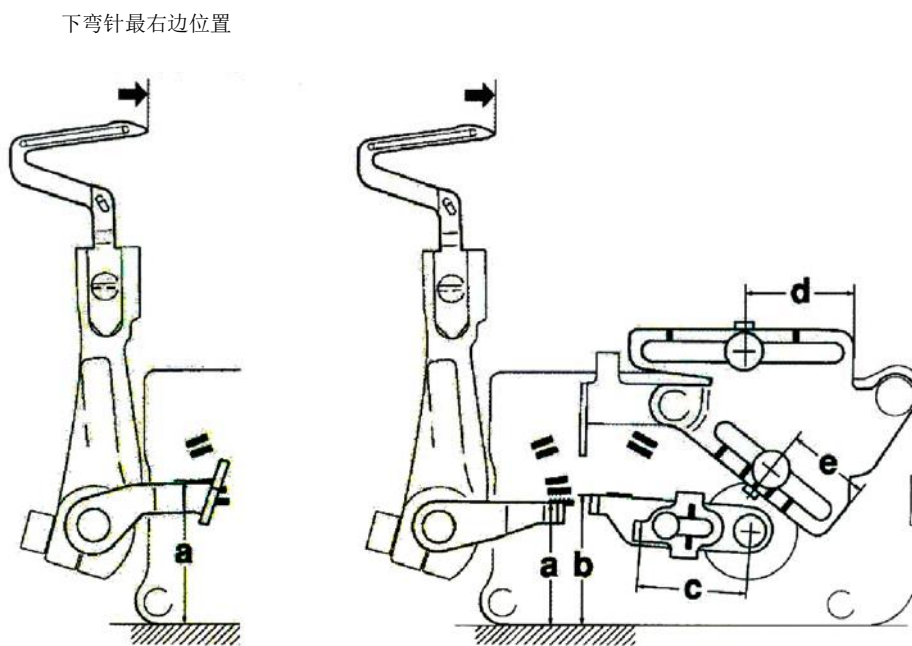
三、四线系列

(mm)

子型号									
			(a)	(b)	(c)	(a)	(b)		
HX6904T-03	10.4 - 10.6	3.7 - 3.9	13.5	5.4 - 5.7	10.5	0.5	0.2	0.7 - 0.9	5.5
HX6914T-03	10.4 - 10.6	3.7 - 3.9	13.5	5.4 - 5.7	10.5	0.5	0.2	0.7 - 0.9	5.5
HX6904T-04	11.8 - 12.0	4.1 - 4.3	13.5	5.4 - 5.7	11	0.5	0.2	1.0 - 1.2	7
HX6914T-04	11.8 - 12.0	4.1 - 4.3	13.5	5.4 - 5.7	11	0.5	0.2	1.0 - 1.2	7

标准用针 (三四系列)

子型号	DCX27
HX6904T-03	#11
HX6914T-03	#11
HX6904T-04	#11
HX6914T-04	#11

HX6900T 系列子型号规格表

三 四线系列



布料厚度	子型号	针数(根)	线数(根)	针距(mm)	链幅(mm)	线迹长(mm)	差动比	压脚抬升量(mm)	最高旋转数(r.p.m.)
薄-中厚	HX6904T-03	1	3		4	0.8-3.8	0.8-1.8	5.5	7000
中厚-厚	HX6914T-03	2	4	2	4	0.8-3.8	0.8-1.8	5.5	7000
极厚	HX6904T-04	1	3		4	0.8-3.8	0.8-1.8	5.5	6300
极厚	HX6914T-04	2	4	2	4	0.8-3.8	0.8-1.8	5.5	6300

Safety attention

1. When using the machine, please strictly observe the safety measures as the following items
2. Before using the machine, please read all instructions contained in the instruction manual. Please take care of the manual for handle consult.
3. When using this machine, make sure that all the safety devices are installed to the required location. Forbid to use the machine if the safety devices are not in the right position.
4. The machine shall be operated by the trained operator.
5. When using the machine, safety glasses are recommended.
6. Please turn off the power or unplug the power plug when the following cases happen.
 - 6-1 When threading the stitch, double stitch, segregator and replacing bobbin.
 - 6-2 When changing replacing the stitch, the presser foot, the throat plate, bend stitch, the feed dog, the stitch guard, the folder and the cloth guider.
 - 6-3 Repairing work
 - 6-4 nobody in the working place or leaving the working place
7. The oil, lubrication used in the machine and the peripheral device flow in eyes or skin, or drinking mistakenly, please wash the correlation parts and go to hospital.
8. Prohibit to touch the power on/off accessory and devices of the machine with oil hand .
9. The repair, alteration, adjustment about the machine should be carried out by professional staff.
10. General repair and maintenance of the machine should be carried out by trained staff.
11. Repair and maintenance about electrical aspects of the machine should be done by professional staff or experts.
12. When repairing, preserving the accessory about the air, compressed air cylinder , the air compressor to supply source should be cut off.
13. The sewing machines should be regular cleaned while using.
14. The machine should be connected to ground wire for safe operation. It should be used against strong noise such an high-frequency welding machine.
15. Electrical power plug should be installed by trained staff. Power plug must be connected to the ground.
16. Sewing machine can not be used other than the designated purpose.
17. Alteration and modification of the machine should be accorded to safety requirements and effective safety measures should be taken. In addition, we assume no responsibility for alteration and modification.
18. The instructions using the following two warnings signs.



Dangerous to operators, maintenance staff.

Be sure to study very carefully for safety



Special attention needed for safety.

Precautions for safety use of the machine



Dangerous

1. To prevent electric shock, please do not open the shell of the control box or touch the control box parts when power on.



Notice

1. Please do not operate the machine when the safety devices ,such as, belt cover, eye guide are unload in order to prevent personal injury.
2. To prevent being involved in accidents of life, please use the motor with motor protection hood.
3. Please do not operate the machine when the power ground is unpacked in order to avoid electric shock.
4. To prevent being involved in personal injury, please do not put your fingers, hair, clothes near the pulley when the machine is running , and do not put anything above the machine.
5. To prevent personal injury, please don't let your fingers near to cloth cutting and stitch after turning on the power or the machine in operation.
6. To prevent personal injury, when the machine is in operation, do not put your finger in the eyeshield
7. To prevent electric shock, leakage, fire accident, be sure to turn off the power of the sub-machine before draw or insert the power plug with your hand.
8. To prevent personal injury due to sudden starts, be sure to turn off the power when leaving the machine.
9. To prevent personal injury due to sudden starts, turn off the power after a power outage.
10. In order to prevent personal injury due to a sudden start, when disassembling motor shield, be sure to turn off the power and the foot pedal is firmly fixed.
11. To prevent personal injury due to sudden starts, when repair, adjusting, removing, threading, replacing stitch, be sure to turn off the power , and the foot pedal is firmly fixed.
12. To prevent personal injury due to falling the machine, please do not hand carry shield cover when sewing machine. Take shield cover off, the shield will open, this will result in the falling of the machine.

LIST

1. Introduction.....	5
2. Instructions of dangers, warnings, cautions.....	5
3. Safety precautions	
➤ Circumstances.....	6
➤ Safety measures.....	6
4. Notes for each procedure	
➤ Unpacking.....	7
➤ Transportation.....	8
➤ Installation, preparation.....	8
➤ Handling machine oil.....	9
➤ Before using the machine.....	9
➤ Before using the machine.....	9
➤ Maintenance Check Repair.....	10
5. Location of warning labels and safety devices.....	11
6. Protectors for safety	
➤ Eyes guard.....	12
➤ Finger guard.....	12
➤ Presser foot.....	12
➤ Front cover.....	12
7. General issue of operation	
➤ Schematic diagram of the sewing machine table.....	13
➤ Lubrication.....	14
➤ Silicone oil for H.R. device.....	15
➤ Oil replacement.....	15
➤ To drain the oil.....	15
➤ Checking and replacing the filter.....	15
➤ Clean the machine.....	16
➤ Adjusting the thread tension.....	17
➤ Opening/closing the presser bar.....	17
➤ Adjusting presser foot pressure.....	17
➤ Adjusting the differential feed ratio.....	17
➤ Adjusting stitch length.....	18
➤ Replacing the upper knife.....	18
➤ Replacing the lower knife.....	18
➤ Adjusting overedge width.....	18
➤ Sharpening the knives.....	19
➤ Change the presser foot pivot.....	19
➤ Positioning and adjusting the needle thread take-up.....	20

Be sure to study very carefully for safety

- Positioning the thread guides/Adjusting the amount thread to be supplied from the needle thread take-up.....20
- Positioning the looper thread take-up and thread guides.Adjusting the amount of thread to be supplied from the looper thread take-up..... 22

1. Introduction



- This instruction manual describes how to use our products safely.
- Read this instruction manual and learn very carefully how to operate, adjust and service this sewing machine before beginning any of the procedures.

2. Indications of dangers, warnings and cautions









To prevent accidents and ensure safety, warning indications which show the degree of danger are used on our products and in this manual.

Follow all warnings and instructions. Indication labels should be found easily. Attach new labels when they are stained or removed. Contact our sales department when new labels are needed.

Symbols, signs and/or signal words which attract users`attention

 DANGER	Indicates an immediate hazard to life or limb.
 WARNING	Indicates a potential hazard to life or limb.
 CAUTION	Indicates a possible mistake that could result in injury or damage

Symbols and messages

	Be sure to follow the instructions when operate the machine.
	It`s dangerous to get an electrical shock.
	It`s dangerous to injure your hands or fingers.
	Indicates a danger of burn injury due to high temperature.
	Never do this.
	Shut off the power when checking, adjusting and repairing the machine or when lightning may strike.
	Be sure to ground the machine and labor saying device securely.
	Denotes the normal rotating direction of the machine pully.

3. Safety precautions

➤ Circumstances

The environment in which our industrial sewing machines are used may seriously affect their lives, functions, performance and/or safety.



For safety, do not use the machine under the circumstances below.

1. Do not use the machine near objects which make noise such as a high - frequency welder, etc.
2. Do not use or store the machine in the air which has vapor from chemicals, or do not expose the device to chemicals.
3. Do not leave the machine outside, in high temperatures or the direct sun.
4. Do not use the machine in the places of high ambient temperature and humidity that seriously affects sewing machines.
5. Do not use the machine on the condition that the voltage fluctuation range is more than $\pm 10\%$ of the rated voltage.
6. Do not use the machine in the place where the supply voltage specified for the control motor cannot be properly obtained.

➤ Safety measures



(1) Safety precautions when you perform maintenance on the machine.

- Always turn off the power unplug the machine and then make sure that the machine does not run by pressing the treadle before performing any maintenance, such as checking, repairing, cleaning, etc. However, if you need to perform these procedures with the power on, to prevent accidents due to the unexpected start of the machine and users` misoperation, establish your own procedures for safely and follow them.
- Always turn off the power and unplug the machine before performing the procedures shown below
 - Lubrication
 - Threading
 - Cleaning
 - Replacing the needle
 - Checking/replacing the oil element
 - Replacing the oil
- Always turn off the power and unplug the machine before performing the procedures shown below
 - Adjusting the stitch length
 - Adjusting the differential feed ratio
- Only well-trained people should perform routine daily maintenance and/or repair the machine.



- Do not modify the machine yourself

※Consult your local Hikari sales office or representative for modification.



(2) Before operating the machine

- Check the machine head and unit for any damage and/or faulty function at the start of each day. If there should be something wrong with the machine, immediately perform repair and/or other necessary procedures

- Check by hand to see if the needle holder is secured.
 - ※ Be careful of the needle point.

- Before starting the machine, make sure that the presser foot is positioned correctly (turn the machine pulley slowly by hand to see if the needle point is centered in the needle drop hole on the presser) (Fig.1)

- Check to see if the presser foot is secured (raise the presser foot by the foot lifter and press it by hand front to back and left to right) (Fig.2)

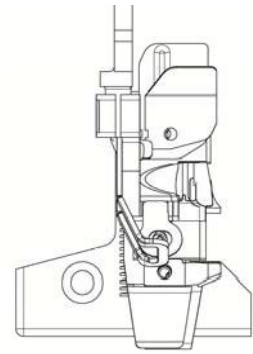

Fig.1



(3) Training

- To prevent accidents, operators and service/maintenance personnel should have proper knowledge and skills for safe operation. To ensure so, managers must design and conduct training for these people.

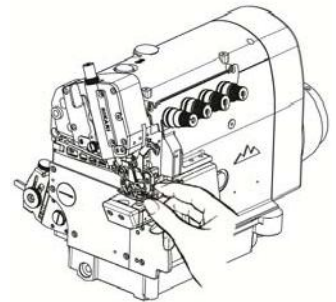

Fig.2

4. Notes for each procedure

➤ Unpacking

1. The machine is packaged in a cardboard box before shipping. Unpack your machine in orderly sequence while checking them right-side up by referring to the indications, such as logo, etc. printed on the boxes.
2. Never hold the area near the needle and/or thread guide related parts when tanking out the machine from the cushion. Otherwise it may cause injury and/or damage to the machine.
3. Take out the machine very carefully while checking the position of the center of the gravity.
4. Keep the cardboard box and packing carefully in case secondary transport is needed in the future.

Disposal of the packaging

- The packaging material of the machine consists of wood, paper, cardboard and VCE fiber. The proper disposal of the packaging is the responsibility of the customer.

Disposal of machine waste

1. The proper disposal of machine waste is the responsibility of the customer.
 2. The materials used on the machines are steel, aluminum, brass and various plastics.
 3. The machine waste is to be disposed of in accordance with the locally valid environmental protection regulations. A specialist should be commissioned if necessary.
- ※ The parts contaminated with lubricants should be disposed off separately according to the locally valid environmental protection regulations.

WARNING

➤ **Transportation**

1. The machine should be carried by at least more than two people when it is mounted on the table and/or a hand truck. Be sure to use a hand truck for other transportation.
2. To carry the machine, hold the machine pully tightly with your right hand and the machine arm with your left upper arm. If the machine and/or your hands are stained with oil, the machine may be easy to slip out of your hands and fall to the floor. Therefore, wipe off the oil carefully.(Fig.3)
3. Care should be taken to avoid excessive shock and shake when the machine is mounted on the table and/or transferred using a hand truck. Otherwise the machine may fall down.
4. Wipe off the oil from the machine before packaging it again for secondary transport. Otherwise the machine may easily slip out of your hands or the bottom of the box may come off while in transit.

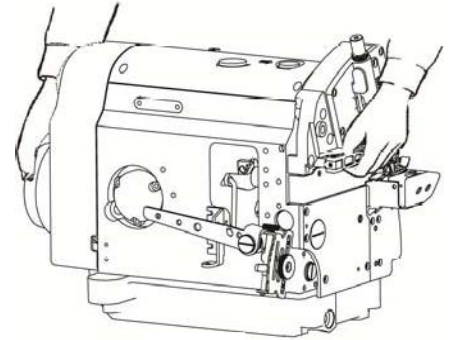

Fig.3

CAUTION



➤ **Installation, preparation**

Machine table

1. Use the machine table(table board, metal legs)that completely carries the machine and is fully resistant to warping while the machine is running.
2. Arrange the working environment for easy operation by consideing where to place the machine and the brightness around the working area. If the illumination is insufficient, control or change lighting as required.
3. Attach a non-slip pad to the treadle(foot switch). Otherwise the operator may slip off the treadle while running the machine, causing trouble.
4. Adjust the height of the table according to a working posture of the operator.

WARNING

Cables

1. When connecting the cables between the machine and the motor, be sure to turn off the power and connect each cable connectors securely.
2. Do not strain the cables in use.
3.  Do not bend the cables in use
4. When connecting the cables that are close to the moving parts, such as motor, keep a distance of 25mm at least between them.
5. Protect each cable using a cover or adjusting its position if necessary
6.  Never use staples to fasten the cables. Otherwise it causes a short circuit and/or a fire.

 **CAUTION**

Ground

1. Install the machine motor correctly by referring to the instruction manual supplied by the manufacturer.
2.  Connect the ground wires securely to the indicated ground points on the machine head.

 **WARNING**

➤ **Handling machine oil**

1. Never start the machine with no oil in the reservoir Use **HIGH SPEED SEWING MACHINE OIL**(Equivalent of ISO requirements:Viscosity Index of Vg22)
2. If machine oil gets in your eyes,it may cause eye irritation.To prevent the machine oil from getting in your eyes, wear a pair of protective glasses.
※Should machine oil gets in your eyes, wash them with fresh water for 15 minutes and then go to see a doctor.
3. Avoid skin contact. Immediately wash contacted areas completely with water and soap.
4.  Never swallow machine oil.
5. Keep machine oil out of the reach of children. If swallowed, do not induce vomiting. Immediately go to see a doctor.
6. Dispose of the waste oil and/or containers properly as demanded by law. If you have further questions on its disposal, contact the store or shop at which you purchased it.
7. After opening the oil container, be sure to seal it to prevent dust and water from getting into the oil and keep it in the dark to avoid direct sunlight.

 **WARNING**



➤ **Before starting the machine**

Machine table

1. Before turning the power on, visually check the cables and connectors for defective conditions, such as damage, disconnection and/or loosening.
2. Never bring your hands close to the needle and/or motor when turning on the power.
3. Well trained operators should use the machine after studying these precautions and the instruction manual carefully.
4. Regarding symbols that indicate a danger or a warning, read and study:"2. Warning indications" carefully and give training on safety to the operators as required.
5. Run the machine at the speed less than 3/4 of its maximum for the first one month.

WARNING

Precautions while you are running the machine

1.  Do not run the machine with the safety devices removed, such as eye guard, finger guard, etc.
2.  Never bring your hands under the needle while running the machine.
3. Never bring your fingers, hair and/or clothes close to the machine motor, thread take-up and/or needle bar. Never put scissors, tweezers, tools around the area stated above.
4. Always turn off the power while the machine is not used or before leaving the machine table.
5. In the event of a power failure, be sure to turn off the power
6. While operating the machine , wear clothes that cannot be caught in the machine.
7. Do not put any tools or other unnecessary objects on the machine table while running the machine.

CAUTION

Maintenance, Check, Repair

1. Well trained people should perform maintenance, check and repair of the machine after studying these precautions and instruction manual carefully.
2. If it is necessary to lay the machine backward for maintenance, check and repair, always turn off the power unplug the machine and press the treadle to make sure that the machine dose not operate before beginning any of the procedures.
3. Carry out daily maintenance work and periodical inspections properly by following these precautions and the instruction manual.
4. Employ Hikari genuine parts when repairing the machine and/or replacing the parts. We are not responsible for accidents cause by any improper repair/adjustment and substituting other parts for those manufactured by Hikari.
5. Do not attempt to modify the machine at your own discretion. We are not responsible for accidents cause by the modification.
6. Be sure to replace the safety devices and/or safety covers that are temporarily removed for maintenance and/or adjustment.
7. After performing maintenance, check and repair , make sure that turning on the power does not pose any danger to you.

5. Location of warning labels and safety devices



图 4

6. Protectors for safely

This chapter describes each protector for safety. Therefore, read and study the following carefully

CAUTION

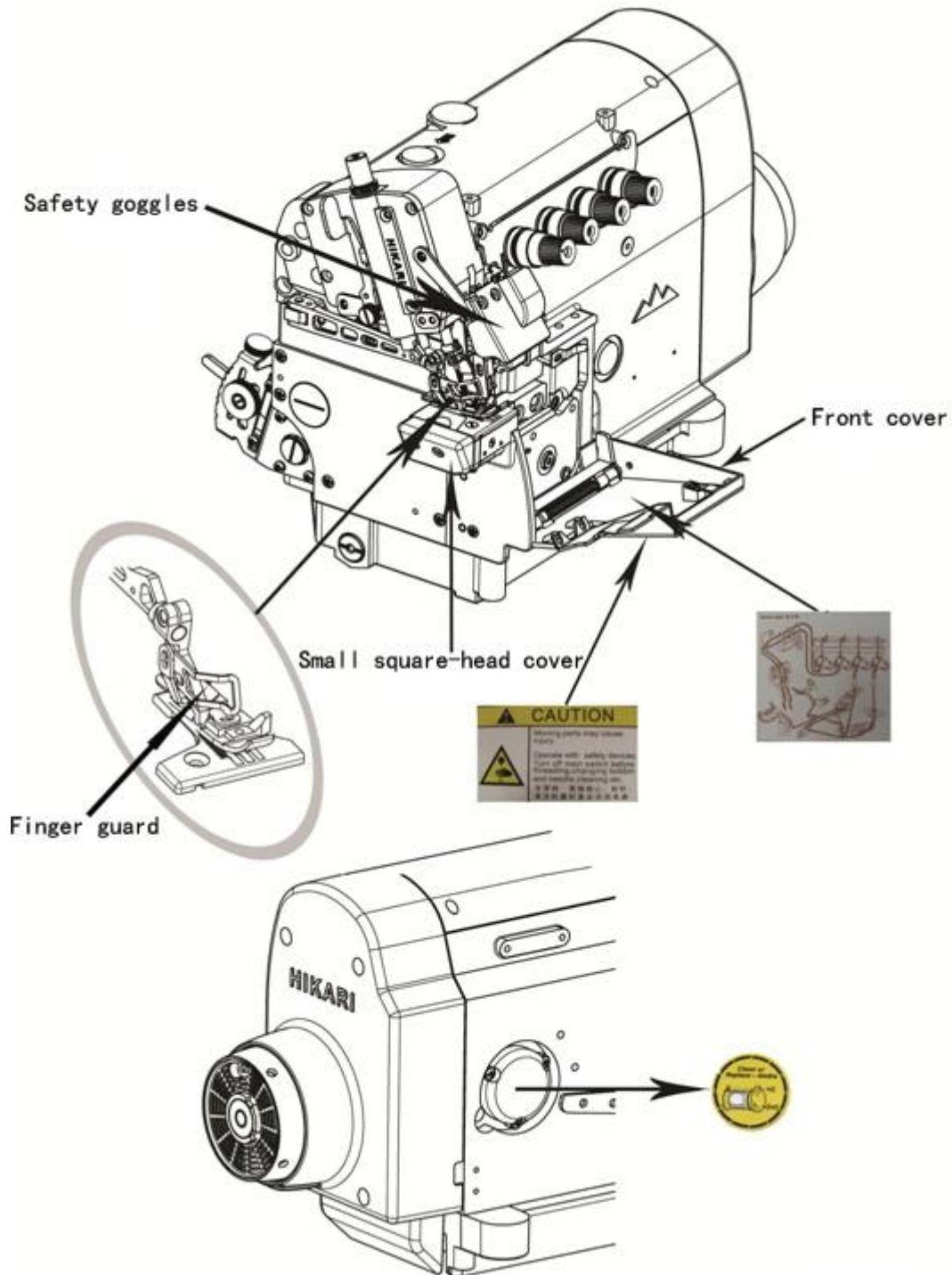
Protectors for

➤ **Eye guard**

- ⊘ Never leave the eye guard open

For the safety of eyes, do not operate the machine with the eye guard open. The eye guard will prevent any pieces of the broken needle from getting into your eyes if the needle should break during sewing.

➤ **Finger guard**

- ⊘ Never insert any of your fingers.

To prevent the needle that moves up and down from contacting any of your body, the finger guard is installed close to the needle. However, there is clearance above the finger guard for easy threading. Be careful that the needle may penetrate any of your fingers if you insert it into this clearance.

➤ **Presser foot**

- ⊘ Never insert any of your fingers.

There is a clearance of more than 5mm between the top surface of the needle plate and the presser foot. Be careful that none of your fingers are caught in this clearance. Never insert any of your fingers under the presser foot when raising the presser foot with the knee switch or automatically raising it with the treadle.

➤ **Front cover**

- ⊘ Never insert any of your fingers.

The looper travels left to right while drawing an arc as seen from the front of the machine. To prevent the looper from contacting any part of your body, be sure to operate the machine with the front cover closed securely.

➤ **Finger protector plate**

- ⊘ Never insert any of your fingers.

When switch the power, never put your finger to the finger protector plate in case of danger caused by trimming knife's hurting because of wrong signal movement.

7. General issue of operation

➤ Schematic diagram of sewing machine table



图 5

Be sure to study very carefully for safety

➤ Lubrication

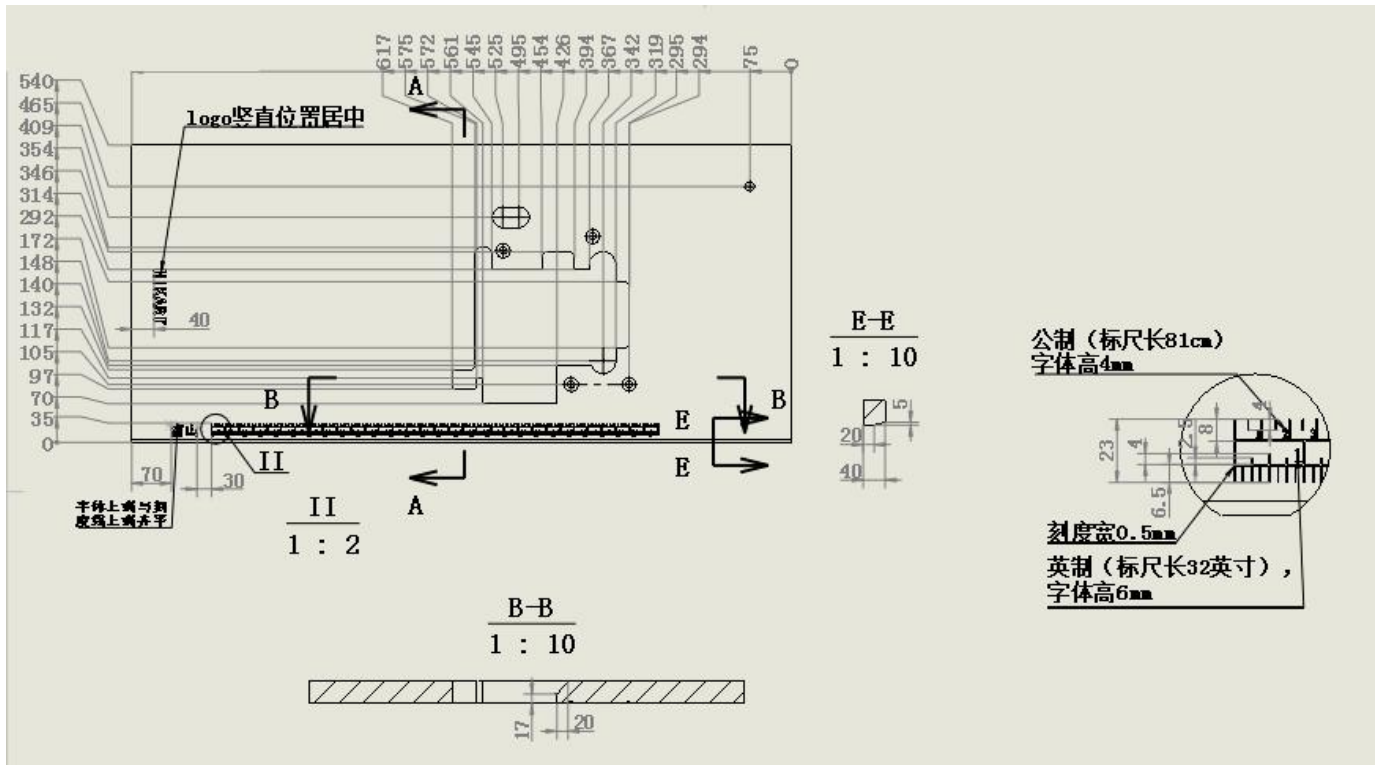

CAUTION

When lubrication the machine and/or replacing the oil, use our company recommended oil. Using other oils may damage machine.

1. Oil

Use the oil "HIGH SPEED SEWING MACHINE OIL" specified by our company (ISO Viscosity Grade 22).

2. To fill the machine with oil (Fig.6)

Remove cap 1, add the oil until the oil level (see oil gauge 2) reaches (H).

After filling the tank with oil replace cap 1.

3. Required amount of oil (Fig.6)

(H) on oil gauge 2: Upper limit

(L) on oil gauge 2: Lower limit

The oil level should always lie between (H) and (L).

4. Manual lubrication (Fig.7)



CAUTION

Always turn off the power and unplug the machine when you apply oil by hand.

Apply 2 or 3 drops of oil to needle bar 3 and upper looper holder 4 by hand when the machine is used for the first time or has been left unused for some time.

5. Checking oil circulation (Fig.8)

Once the machine has been properly filled with oil, press the machine treadle to run the machine and check oil gauge window 5 to see if the oil is flowing.

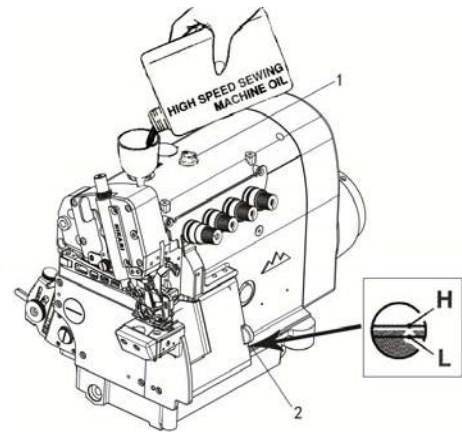

Fig. 6

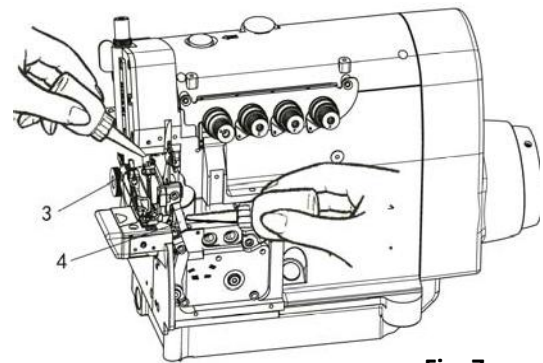

Fig. 7

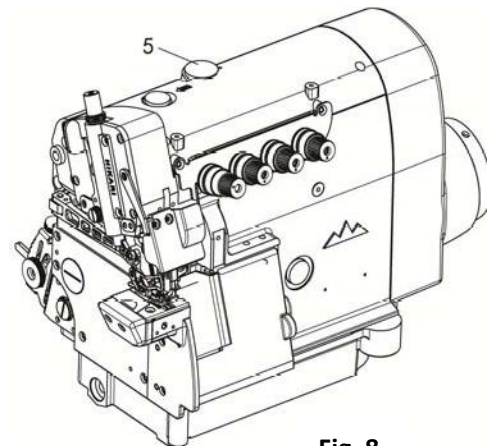

Fig. 8

➤ **Silicone oil for H. R. device**

CAUTION

Always turn off the power and unplug the machine when you fill the H.R. device with silicone oil.

Fill silicone oil tanks 1, 2 with silicone oil.

To prevent thread breakage or fabric damage, add the silicone oil before it is too low. (Fig.9)

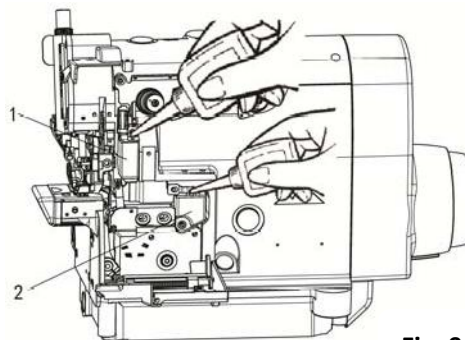

Fig. 9

➤ **Oil replacement**

CAUTION

Well-qualified technicians should replace the oil.

Replace the oil one month after the first use and thereafter every six months. If you keep using the old oil, it may cause the damage to the machine.

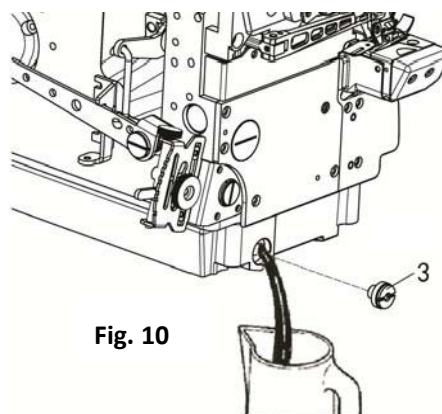

Fig. 10

➤ **To drain the oil**

1. Drain the oil by removing screw 3 on the left side of the oil pan.
2. Tighten screw 3 after draining (Fig.10)

➤ **Checking and replacing the filter**

CAUTION

Always turn off the power, unplug the machine and then well-qualified technicians should check and replace the filter.

If filter 7 is clogged up with dust and dirt, the machine will not be properly lubricated.

Check filter 7 every six months, and clean or replace it if necessary.

To remove the filter (Fig.11)

Remove parts 4 to 7, and check the filter by referring to the illustration. If filter 7 is completely damaged, replace it with a new one.

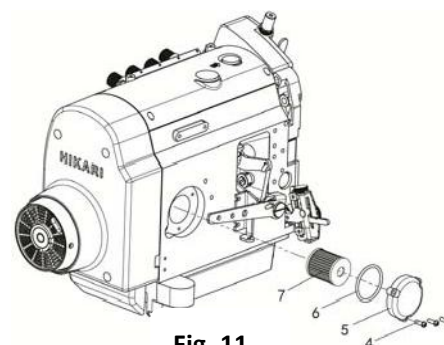

Fig. 11

➤ **Cleaning the machine**

CAUTION

Always turn off the power and unplug the machine when you clean the machine.

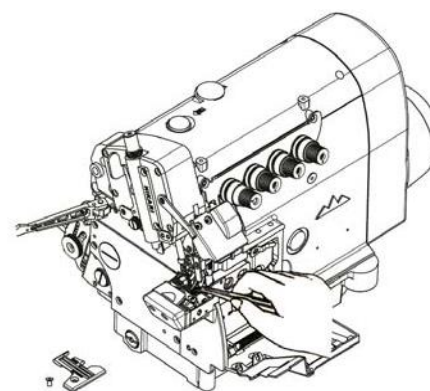

Fig. 12

Be sure to study very carefully for safety

Clean the grooves of the needle plate and the area around the feed dogs (Fig.12)

➤ **Threading**

CAUTION

Always turn off the power and unplug the machine when you thread the machine.

1. Open cloth plate 1, eye guard 2, front cover 3, and presser bar 4. Put each part back after threading the machine (Fig.13).

2. In case the machine is threaded previously (Fig.14)

A: Knot the preset thread and the thread being used together to thread the machine.

B: Needle thread

Pull the knot toward the needle, trim the knot off and then thread the needle.

C: Looper thread

Trim the knots off neatly after passing through the eye of the looper.

3. If the machine is not threaded

Thread the machine properly by referring to the label attached to the machine.

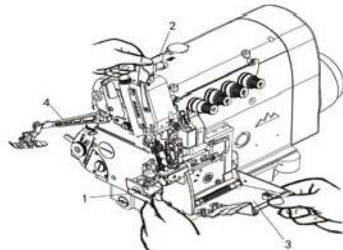

Fig. 13

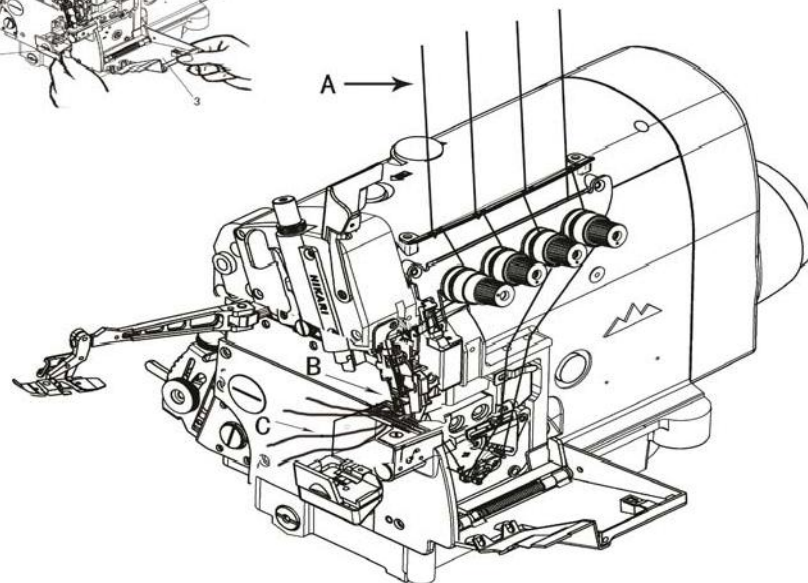

Fig. 14

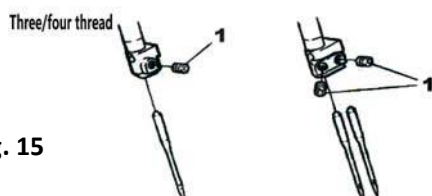

Fig. 15

Replacing the needle



CAUTION Always turn off the power and unplug the machine when you replace the needle(s).

To replace the needle, loosen screw 1 firstly by referring to the illustration below (Fig.15, 16)

Turn the scarf to the rear of the machine as seen from the front of the machine, insert the needle to the proper depth, and fasten screws 1 securely (Fig.17).

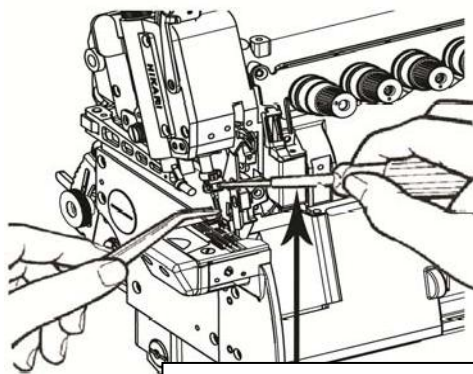

Fig. 16

please use the red handle of the wrench(attachment)

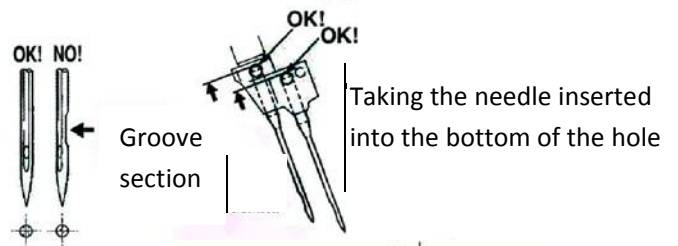

Fig. 17

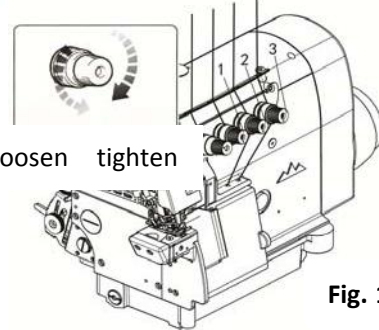

Fig. 18

➤ **Adjusting the thread tension**

To obtain the proper thread tension, adjust needle thread tension knobs 1, top cover thread tension knobs 2 and looper thread tension knob 3 (Fig.18) . To tighten the thread, turn each knob clockwise. To loosen the thread, turn each knob counter clockwise. Each thread tension should be as light as possible, yet sufficient to produce balanced and beautiful stitches.

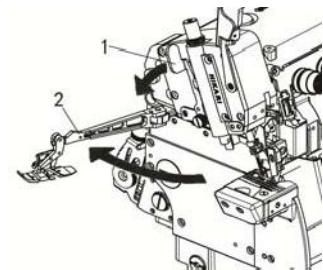

Fig. 19

CAUTION

Always turn off the power and unplug the machine before opening/closing the presser bar.

To open the presser bar (Fig.19)

1. Rotate the handwheel until the needle is at the top of its stroke.
2. Bring lever 1 down to open presser bar 2.

To close the presser bar (Fig.19)

1. Rotate the handwheel until the needle is at the top of its stroke.
2. Bring lever 1 down to put presser bar 2 back.

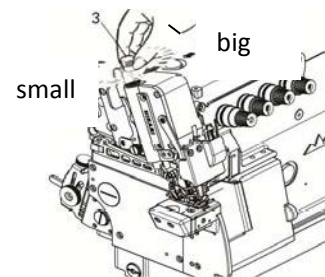

Fig. 20

➤ **Adjusting presser foot pressure**

The presser foot pressure should be as light as possible, yet sufficient to feed the fabric correctly and provide the uniform stitch formation.

Adjust presser foot pressure by turning adjustment screw 3. (Fig.20)

➤ **Adjusting the differential feed ratio**

1. Loosen nut, to increase the differential feed ratio, bring lever down. The finished fabric is shrunk. To decrease the differential feed ratio, bring lever up. The finished fabric is stretched.

2. After this adjustment is made, tighten nut. (Fig.21)

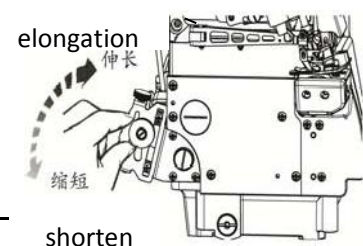

Fig. 21

Be sure to study very carefully for safety

➤ Adjusting stitch length



CAUTION

Always turn off the power and unplug the machine when adjusting the stitch length.

1. With push button 1 depressed, turn handwheel 2 so that the push button 1 goes further into the depth (Fig.22).
2. With the push button in the place stated in 1. Turning handwheel 2 counterclockwise produces coarse stitches. Turning handwheel 2 clockwise produces fine stitches (Fig.22).

NOTE:

Stitch length adjustment must only be made after the differential feed ratio has been

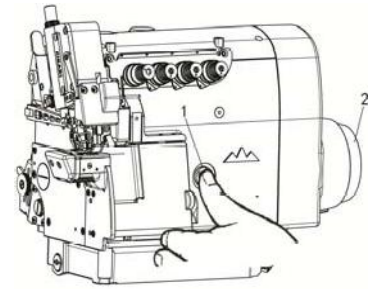

Fig. 22



CAUTION

Always turn off the power, disconnect the power cord and then only well-qualified technicians should replace and adjust the knife. Pay attention to the knife edges not to injure your hands and fingers.

➤ Replacing the upper knife

1. Loosen screw 1. Bring lower knife holder 2 to its farthest position to left. Tighten screw 1 temporarily.
2. Remove screw 3 and upper knife 4. Replace the upper knife with a new one. Tighten screw 3 temporarily. Turn the handwheel until the upper knife holder is at its lowest position. There should be 0.5-1.0mm overlap of the upper and lower knives. Adjustment is made by moving the upper knife up or down. Tighten screw 3.
3. Cross upper knife 4 and lower knife 6 with each other at the center (A) of their cutting edges (Fig.26). Loosen screw 1. Then check to make sure that the upper knife tightly touches the lower knife. Tighten screw 1.
4. To check proper cutting, place a thread between the upper and lower knives and turn the handwheel.

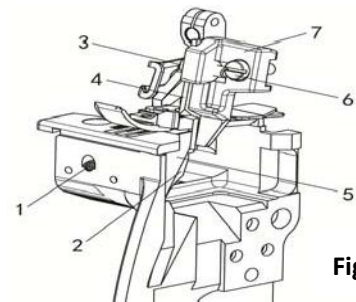

the
Fig. 23

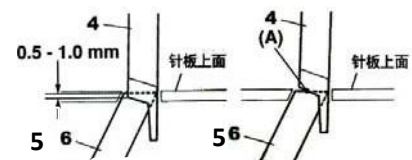

Fig. 24

Fig. 25

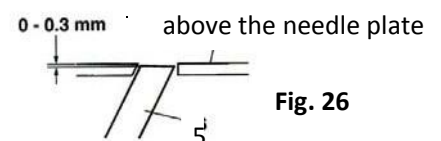

Fig. 26

➤ Replacing the lower knife

1. Loosen screw 1. Bring lower knife holder 2 to its farthest position to the left. Tighten screw 1 temporarily.
2. Loosen screw, remove lower knife, replace it with a new knife. Adjust the lower knife so that the cutting edge is 0-0.3mm below the top surface of the needle plate. Tighten screw 5.
3. Follow procedures 3 and 4 in "Replacing the upper knife".

➤ Adjusting overedge width

1. Loosen screw 1. Bring lower knife holder 2 to the farthest position to the left. Tighten screw 1 temporarily.
2. Loosen screw 6, Adjusting overedge width by moving upper knife clamp 8 to the left or right.

3. Follow procedures 3 and 4 in “Replacing the upper knife”.

➤ **Sharpening the knives**

The upper knife is need to resharpen is for some time. Resharpen the lower knife for the proper cutting action.

Resharpen the lower knife (Fig. 27)

If you resharpen the lower knife improperly, insufficient cutting will be obtain or the lower knife will become immediately dull. Be careful.

Upper knife

A special knife grinder is needed to resharpen the upper knife. It is recommended when resharpening the upper knife that you ask Hikari direct distributors or our agents. To increase efficiency, always prepare a spare upper knife.

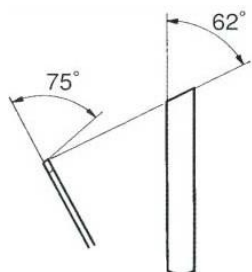

Fig. 27

➤ **Changing the fulcrum on the presser arm**

CAUTION

Always turn off the power, unplug the machine and then well-qualified technicians should change the fulcrum on the presser arm.

1. Set the presser foot, and then bring down the feed dog to the bottom of its travel.
2. Move collar to the right while pressing presser foot shaft in the direction of A, tighten screw. (There should be a clearance of 1mm between presser foot lift lever and upper limit screw.)
3. Check to see if the slot(s) of the needle(s) on the presser foot is (are) aligned with that (those) on the needle plate. If not, loosen fixed presser foot bushings screw, and adjust presser arm by moving it left or right. After this adjustment, tighten screw. (Fig. 28, Fig. 29)

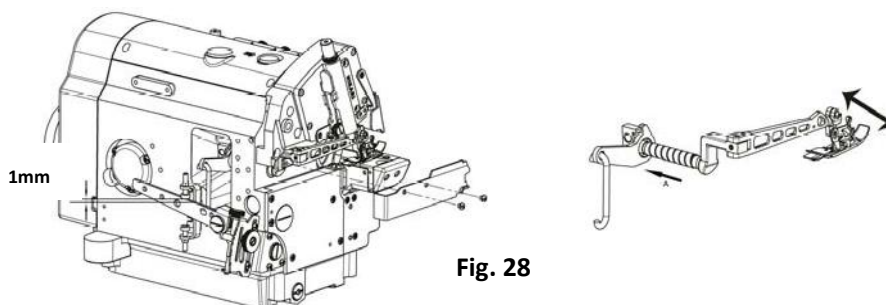

Fig. 28

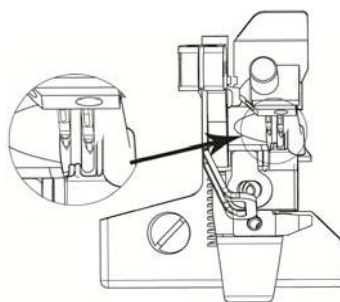

Fig. 29

Be sure to study very carefully **for safety**

➤ Positioning and adjusting the needle thread take - up

CAUTION

Always turn off the power, unplug the machine and then well-qualified technicians should adjust the needle thread take-up.

When needle thread take-up 1 is at the bottom of its travel, adjust the distance from the front of the arm head to the needle thread take-up. To make this adjustment, loosen screws 2. (Fig. 30, 31)

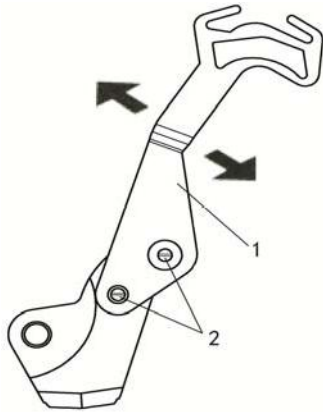

Fig. 30

三、四线
three/four thread

up the joint

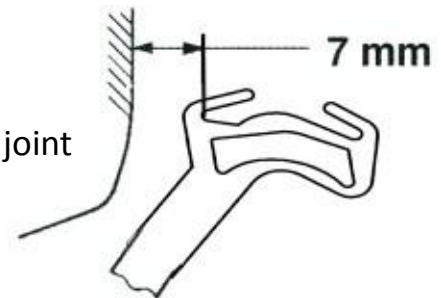

Fig. 31

➤ Positioning the thread guides/Adjusting the amount thread to be supplied from the needle thread take - up

The location of each needle thread guide varies with types of machine. When the needle thread take-up is at the bottom and the top of its travel, position each needle thread guide according to the machine being used.

3, 4 thread series Adjusting the needle thread guides (Fig. 32)

Loosen screws 12 and 14. Adjust thread guides 11 and needle thread bracket 13 by moving them in the direction of the arrows.

To increase the amount of thread to be supplied, move each thread guide, and needle thread bracket in the direction of (+). To decrease the amount of thread to be supplied, moving each thread guide, and needle thread bracket in the direction of (-).

After this adjustment, tighten screws 12 to 14.

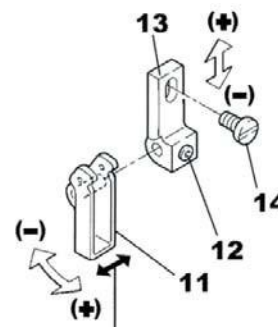

(Fig. 32)

Adjust the left-right position of through thread piece No.11, made the line up piece of needle in the centre of two-ply.

Positioning the thread guides

● HX6904T-03

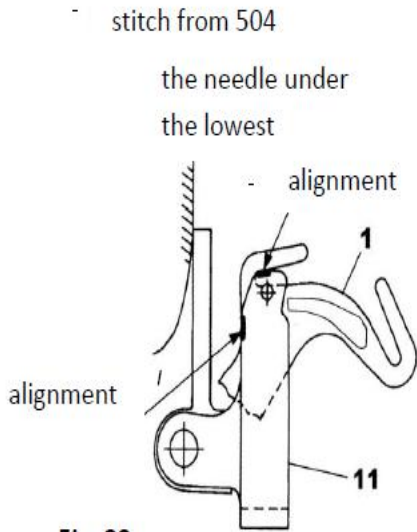

Fig. 33

● HX6905T-03

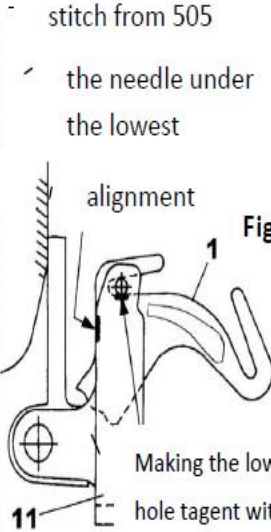

Fig. 34

● HX6914T-03

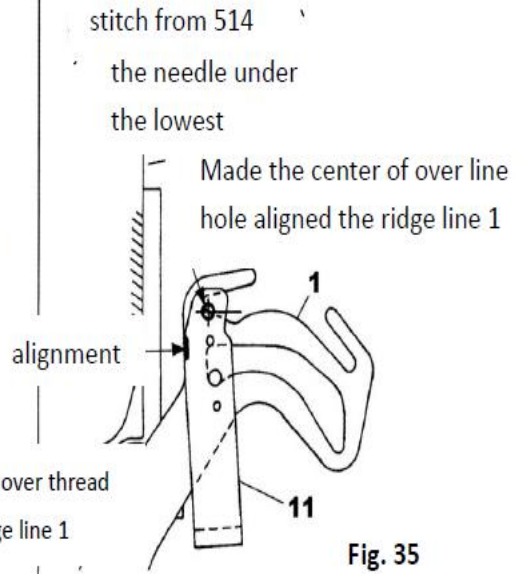

Fig. 35

● HX6904T-03

Stitch type: 504 (soft thread chain)

the needle under the lowest position / the topest position of shelt

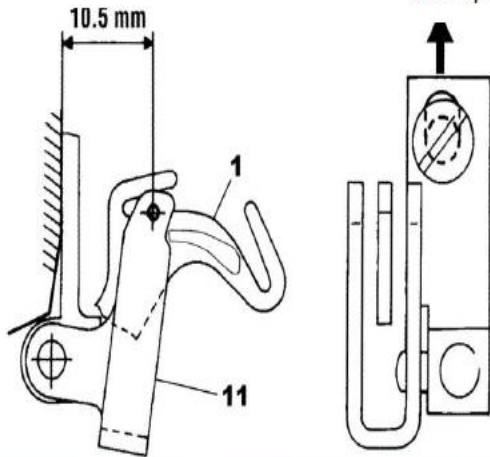

Fig. 36

the needle

Be sure to study very carefully for safety

- **Positioning the looper thread take - up and thread guides. Adjusting the amount of thread to be supplied from the looper thread take - up**

⚠ CAUTION

Always turn off the power, unplug the machine and then well-qualified technicians should adjust the thread take-up.

1. Adjust looper thread take-up 9 and 11 with the lower looper at the extreme right end of it
Position looper thread take-up 9 and 11 by referring to the table below. Loosen screws 10 and 12, and adjust looper thread take-up 9 and 11.

To increase the amount of thread, move looper thread take-up 9 and 11 in the direction of (+).

To decrease the amount of thread, move looper thread take-up 9 and 11 in the direction of (-).

The standard location of looper thread guides

2. 13, 15 and 17 is shown on the next page. Loosen screws 14, 16 and 18, and adjust each looper thread guide (see the illustration).

To increase the amount of thread to be supplied, move each looper thread guide in the direction of (+).

To decrease the amount of thread to be supplied, move each looper thread guide in the direction of (-). (Fig. 37)

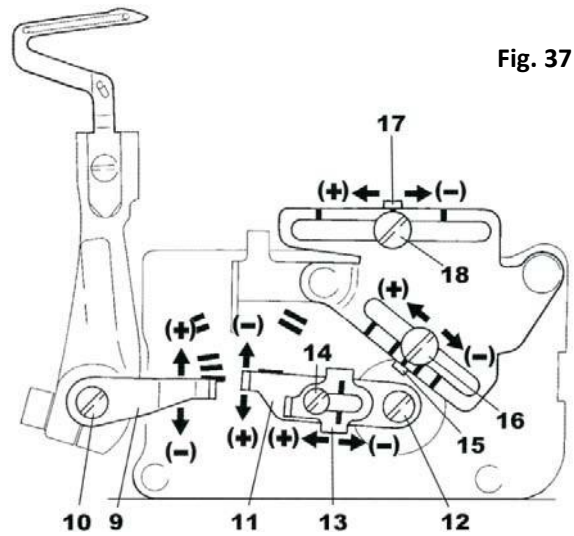

Fig. 37

The standard position of thread looper and thread guides (Fig. 38)

Lower looper at the extreme right end of its travel

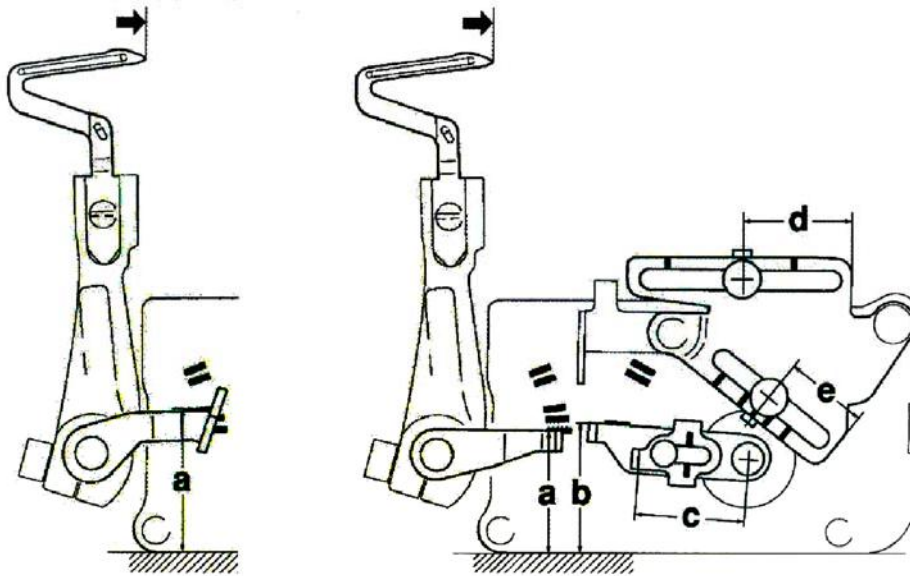

Fig. 38

HX6900T	(a)	(b)	(c)	(d)	(e)
HX6904T-03	26	29	28	21.5	14.5
HX6914T-03	26	29	28	21.5	14.5
HX6904T-04	26	29	28	21.5	14.5
HX6914T-04	26	29	28	21.5	14.5

(mm)

Adjusting the reference table

three/four thread series

(mm)

子型号									
			(a)	(b)	(c)	(a)	(b)		
HX6904T-03	10.4 - 10.6	3.7 - 3.9	13.5	5.4 - 5.7	10.5	0.5	0.2	0.7 - 0.9	5.5
HX6914T-03	10.4 - 10.6	3.7 - 3.9	13.5	5.4 - 5.7	10.5	0.5	0.2	0.7 - 0.9	5.5
HX6904T-04	11.8 - 12.0	4.1 - 4.3	13.5	5.4 - 5.7	11	0.5	0.2	1.0 - 1.2	7
HX6914T-04	11.8 - 12.0	4.1 - 4.3	13.5	5.4 - 5.7	11	0.5	0.2	1.0 - 1.2	7

standard needle(three/four thread series)

Subtypes No.	DCX27
HX6904T-03	#11
HX6914T-03	#11
HX6904T-04	#11
HX6914T-04	#11

HX6900T series type form

three/four thread series



the thickness of fabric	Subclass	Number of needle	Number of thread	Needle space	width of stitch	the length of stitch	Diff.feed rate	Presser foot lift	maximum speed
Medium-heavy	HX6904T-03	1	3		4	0.8-3.8	0.8-1.8	5.5	7000
Medium-heavy	HX6914T-03	2	4	2	4	0.8-3.8	0.8-1.8	5.5	7000
Extra heavy	HX6904T-04	1	3		4	0.8-3.8	0.8-1.8	6.5	6300
Extra heavy	HX6914T-04	2	4	2	4	0.8-3.8	0.8-1.8	6.5	6300

此说明书仅作参考，如有更改恕不另作通知。

This manual is only for reference.

If there is any modification, we apologize for the changing hence caused.



富山IoT



微信公众号



抖音官方号

上海富山精密机械科技有限公司

HIKARI (SHANGHAI) PRECISE MACHINERY SCIENCE AND TECHNOLOGY CO., LTD

邮箱/E-mail: hikari@chinahikari.com

网址/Web: www.chinahikari.com

传真/Fax: (00)86-21-67311311

电话/Tel: (00)86-21-67311111 (转外贸部/ext .Foreign Trade Dept)

上海市金山区朱泾镇工业园区中达路800号

NO.800, ZHONGDA ROAD, ZHUJING INDUSTRIAL ZONE,

JINSHAN DISTRICT, SHANGHAI CHINA



QUANTITY ATTESTATION
ISO9001质量体系认证